

Moray 25

Production year 2008

Production année 2008

PARTS CATALOGUE

CATALOGUE DE PIÈCES DÉTACHÉES

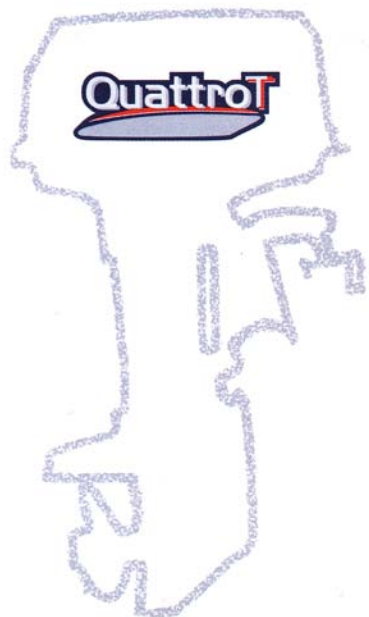

ENGINE STARTING SERIAL NUMBER: 1037173



A1

FOREWORD

This Parts Catalogue is related to the parts for the model(s) on the cover page. When you are ordering replacement parts, please refer to this Parts Catalogue and quote both part numbers and part names correctly.

1. Modifications or additions which have been made after the issue of the Parts Catalogue will be announced in the Parts News.
It is advisable that you make the necessary corrections to the Parts Catalogue according to the Parts News.

2. Abbreviations
The following abbreviations are used in this Parts Catalogue.

“UR” Use specified parts number.
 “UN” Use as many as needed.
 “AP” Alternate Parts
 “LM” Locally Made (Parts need to be ordered locally)
 “F#” Frame No. (Applicable machine No.)
 “O/S” Over Size

3. The number of components for assembly
 - Parts, which are to be supplied in an assembly, are listed with a dot (.) in front of the part name as shown below.
 - The numeral appearing to the right of each component part indicates the quantity of parts for each assembly unit.

PART NO.	DESCRIPTION	Q'TY	REMARKS
2F5-83310-60	FRONT FLASHER LIGHT ASSY	2	
115-83311-60	.BULB (6V-18W)	1	

4. Applicable colours of graphics are represented in the “REMARKS” as shown below.

PART NO.	DESCRIPTION	Q'TY	REMARKS
2N4-24110-00-X5	FUEL TANK COMP.	2	MXR
3J1-24240-10	.GRAPHIC, FUEL TANK	1	FOR MXR

5. Note that the illustrations for reference in finding parts numbers are not to be used for assembling. When assembling, please use the applicable service manual.

6. The asterisk (*) before a reference number indicates modified items after the first edition.
7. Applicable Serial No.

Engine Serial No.

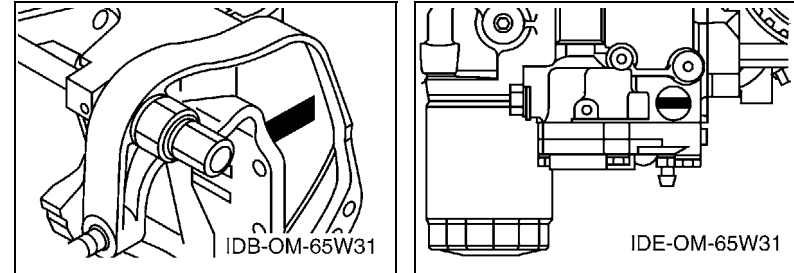

8. Applicable Engine Starting Serial No.

Model	Serial No.	Model	Serial No.
Moray 25	65W-1037173		

9. Applicable Colour Code

Abbreviation	Colour Name	Colour Code
DBNM2	DARK BLUISH GRAY METALLIC 2	004D

10. Quantity Column Information

Column No.	Name Of Q'ty Column	Applicable Model
1	M	F25AMH
2	E	F25AE

CONTENTS

SHEET1/2

TOP COWLING	A4
CYLINDER & CRANKCASE 1	A5
CRANKSHAFT & PISTON	A7
CYLINDER & CRANKCASE 2	B1
VALVE	B3
INTAKE	B4
CARBURETOR	B5
OIL PUMP	B7
FUEL	C1
STARTER	C3
GENERATOR	C5
ELECTRICAL 1	C7
ELECTRICAL 2	D2
ELECTRICAL 3	D4
STARTING MOTOR	D5
BOTTOM COWLING	D6
STEERING	E1
CONTROL	E3
REMO CON ATTACHMENT	E5
BRACKET 1	E6
BRACKET 2	F2
BRACKET 3	F4
POWER TRIM & TILT ASSY	F6

INDEX

NUMERICAL INDEX	G1
-----------------------	----

SHEET2/2

POWER TRIM & TILT ASSY	A4*
UPPER CASING	A5*
OIL PAN	A6*
LOWER CASING & DRIVE 1	A7*
LOWER CASING & DRIVE 2	B3*
FUEL TANK	B4*
STEERING GUIDE	B5*
REMOTE CONTROL BOX	B6*
REMOTE CONTROL ASSY	B7*
REPAIR KIT 1	C3*
REPAIR KIT 2	C4*
REPAIR KIT 3	C5*

INDEX

NUMERICAL INDEX	G1*
-----------------------	-----

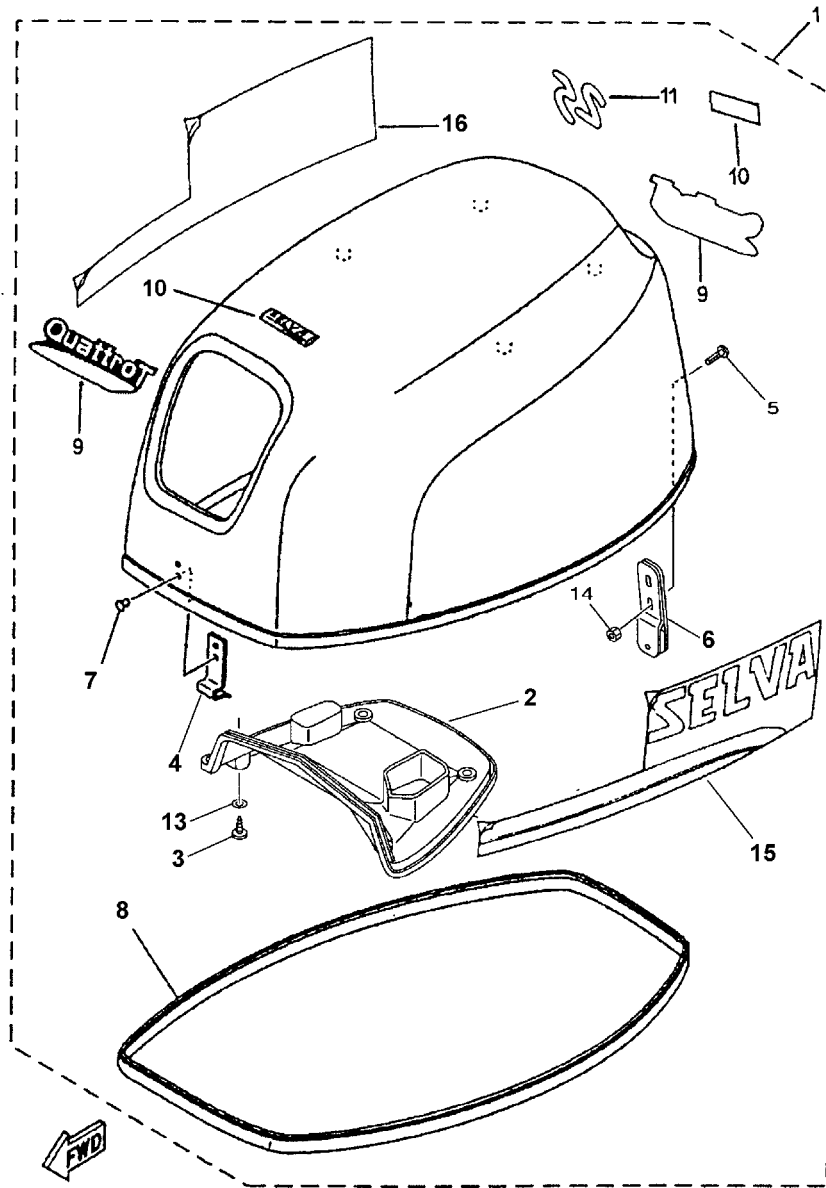
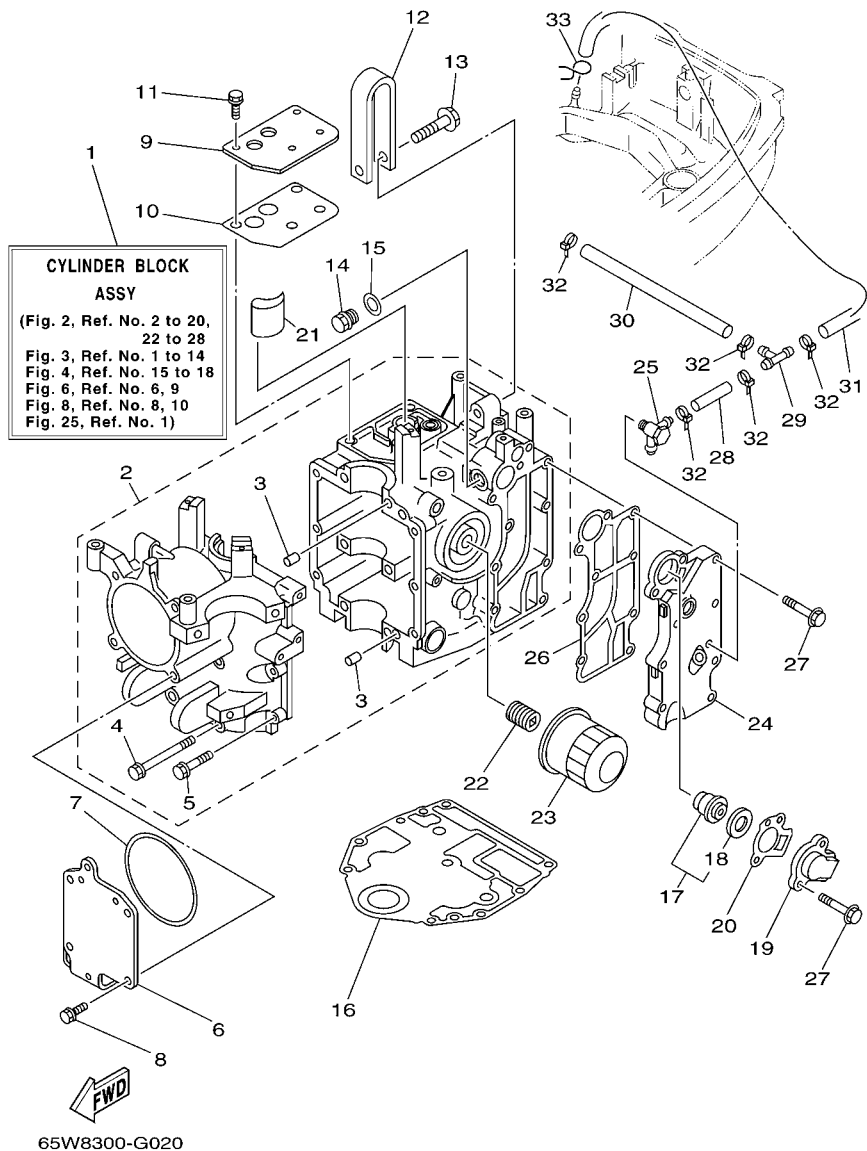

FIG. 1 TOP COWLING

CAPOT SUPERIEUR

REF. NO.	PART NO. N° PIECES	DESCRIPTION DESCRIPTION	M	L		REMARKS REMARQUES
1	1504200	TOP COWLING ASSY CAPOT (ENS.)	1	1		
2	65W-42613-00	.MOLDING, AIR DUCT .MANCHON A AIR	1	1		
3	97780-60520	.SCREW, TAPPING .VIS, TETE BOMBEE	4	4		
4	65W-42651-01	.HOOK .CROCHET	1	1		
5	90109-06MA4	.BOLT .BOULON	2	2		
6	65W-42652-01	.HOOK .CROCHET	1	1		
7	90266-06M02	.RIVET .RIVET	2	2		
8	6D5-42615-00	.SEAL .JOINT	1	1		
9	8092684	.GRAPHIC QUATTRO T .ADHESIF, QUATTRO T	2	2		
10	8092605	.GRAPHIC, SELVA MARINE .ADHESIF, SELVA MARINE	2	2		
11	8092071	.GRAPHIC, 25 .ADHESIF, 25	1	1		
13	90202-05M38	.WASHER, PLATE .RONDELLE, PLATE	4	4		
14	95680-06100	.NUT, U .ECROU, U	2	2		
15	8092670	.GRAPHIC, LEFT .ADHESIF, GOUCHE	1	1		
16	8092668	.GRAPHIC, RIGHT .ADHESIF, DROITE	1	1		
	1533980	.GRAPHIC SET .JEU DIEMBLEMEST	1	1		

FIG. 2 CYLINDER & CRANKCASE 1 CYLINDRE & CARTER 1



REF. NO.	PART NO. N° PIECES	DESCRIPTION DESCRIPTION	MH	E	ET	REMARKS REMARQUES
1	65W-W009B-12-1S	CYLINDER BLOCK ASSY CYLINDRE GROUPE (ENS.)	1	1	1	
2	65W-15100-11-1S	CRANKCASE ASSY CARTER DE MOTEUR COMPLET	1	1	1	
3	99530-08012	.PIN, DOWEL .GOUJON, D'ASSEMBLAGE	2	2	2	
4	90119-08M01	.BOLT, WITH WASHER .BOULON, AVEC RONDELLE	6	6	6	
5	90119-06MA5	.BOLT, WITH WASHER .BOULON, AVEC RONDELLE	6	6	6	
6	65W-15121-01	CRANKCASE 2 CARTER DE MOTEUR	1	1	1	
7	65W-15663-00	SEAL JOINT	1	1	1	
8	65W-12228-00	BOLT BOULON	4	4	4	
9	65W-11168-01	COVER, BREATHER COUVERCLE, RENIFLARD	1	1	1	
10	65W-11169-01	GASKET, BREATHER COVER JOINT, COUVERCLE DE RENIFLARD	1	1	1	
11	65W-12228-00	BOLT BOULON	4	4	4	
12	65W-11119-00	HANGER, ENGINE ANNEAU, LEVAGE	1	1	1	
13	90105-08M87	BOLT, FLANGE BOULON	1	1	1	
14	90340-14M06	PLUG, STRAIGHT SCREW PLOT, FILETE DROIT	1	1	1	
15	90430-14115	GASKET JOINT	1	1	1	
16	65W-11351-10	GASKET, CYLINDER JOINT, D'EMBASE	1	1	1	
17	6G8-12411-03	THERMOSTAT THERMOSTAT	1	1	1	
18	688-12412-00	.SEAL, THERMOSTAT .JOINT, THERMOSTAT	1	1	1	
19	6H3-12413-00-1S	COVER, THERMOSTAT COUVERCLE, THERMOSTAT	1	1	1	
20	62Y-12414-00	GASKET, COVER JOINT, COUVERCLE	1	1	1	
21	65W-13286-00	CLEANER FILTRE	1	1	1	
22	90401-20M00	BOLT, UNION BOULON, RACCORD	1	1	1	
23	5GH-13440-00	ELEMENT ASSY, OIL CLEANER ELEMENT, FILTRE A HUILE	1	1	1	
24	65W-41113-10-1S	OUTER COVER, EXHAUST COUVERCLE, ECHAPPEMENT	1	1	1	
25	62Y-11372-01	NIPPLE, HOSE RACCORD, TUYAU	1	1	1	FLUSHING KIT FLUSHING KIT
26	65W-41114-01	GASKET, EXHAUST OUTER COVER JOINT, COUVERCLE D'ECHAPPEMENT	1	1	1	
27	90119-06MA5	BOLT, WITH WASHER BOULON, AVEC RONDELLE	9	9	9	

FIG. 2 CYLINDER & CRANKCASE 1 CYLINDRE & CARTER 1

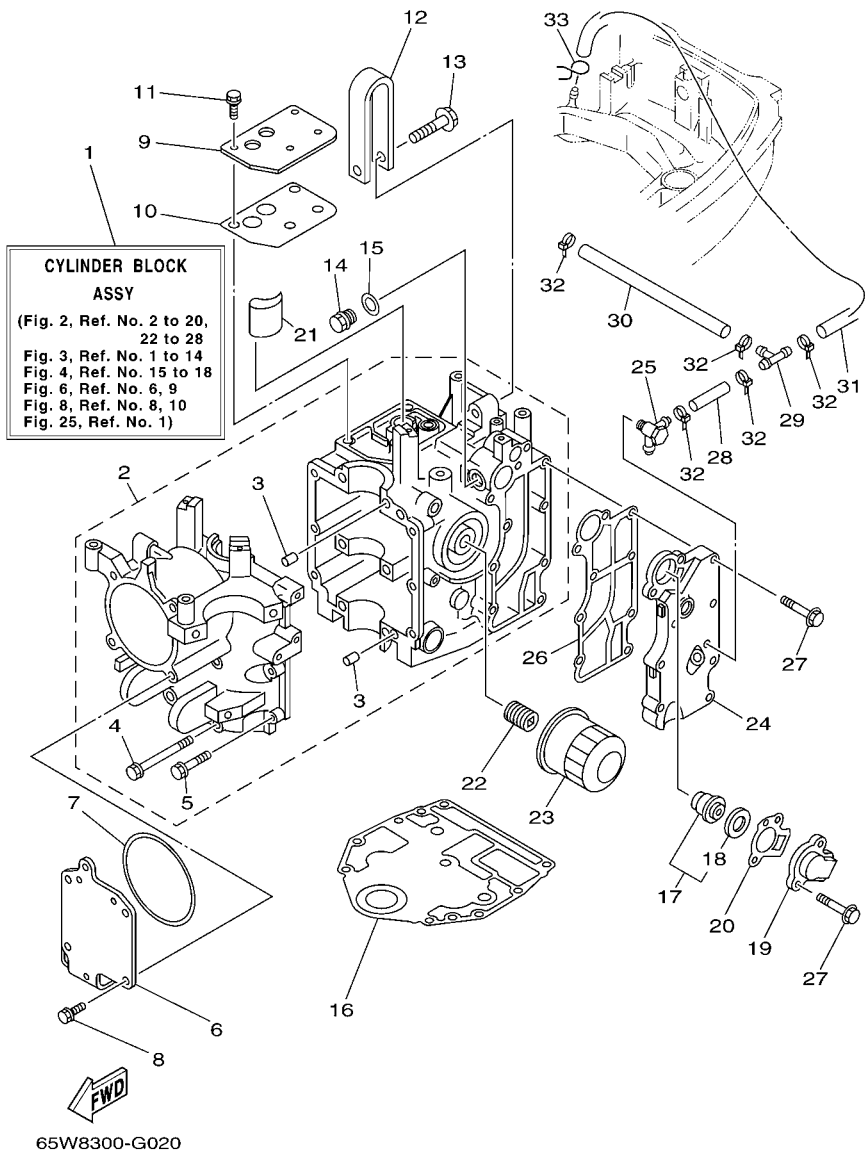

REF. NO.	PART NO. N° PIECES	DESCRIPTION DESCRIPTION	MH	E	ET	REMARKS REMARQUES
28	90445-09068	HOSE (L110) DURITE (L110)	1	1	1	
29	688-24378-00	PIPE, JOINT 3 DURITE RACCORDEMENT 3	1	1	1	
30	90445-09095	HOSE (L215) DURITE (L215)	1	1	1	
31	90445-09104	HOSE (L300) DURITE (L300)	1	1	1	
32	90465-11M10	CLAMP BRIDE	5	5	5	
33	90467-08004	CLIP JONC	1	1	1	

FIG. 3 CRANKSHAFT & PISTON

VILEBREQUIN & PISTON

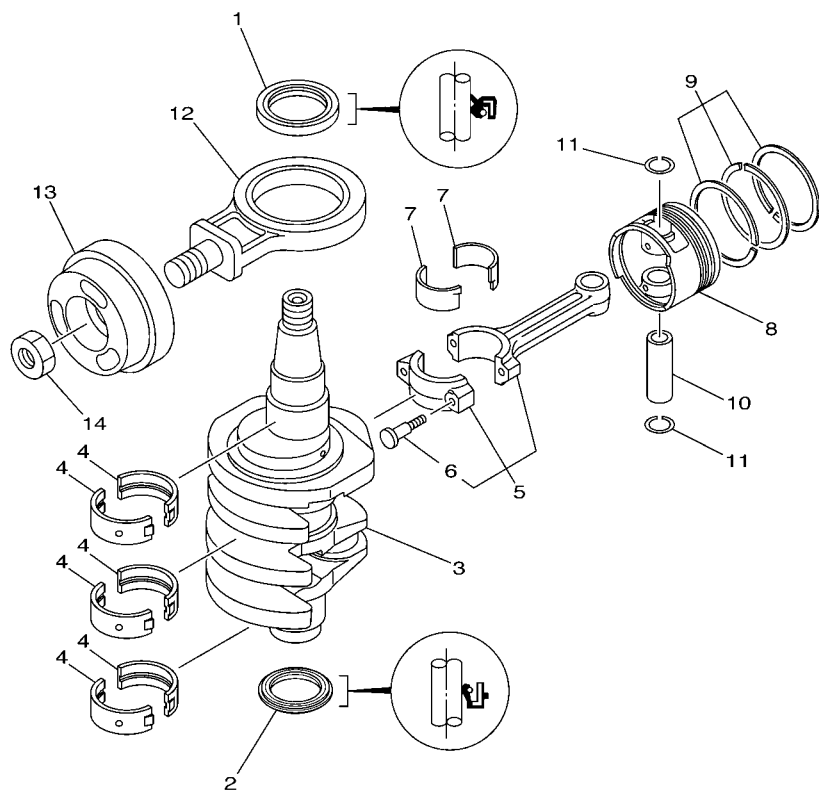

REF. NO.	PART NO. N° PIECES	DESCRIPTION DESCRIPTION	MH	E	ET	REMARKS REMARQUES
1	93102-43004	OIL SEAL JOINT SPY	1	1	1	
2	93101-35002	OIL SEAL JOINT SPY	1	1	1	
3	65W-11411-01	CRANKSHAFT VILEBREQUIN COMPLET	1	1	1	
4	62Y-11416-00	PLANE BEARING, CRANKSHAFT 1 COUSSINET DE VILEBREQUIN 1	6	6	6	UR BROWN UR BROWN
	62Y-11416-10	PLANE BEARING, CRANKSHAFT 1 COUSSINET DE VILEBREQUIN 1	6	6	6	UR BLACK UR BLACK
	62Y-11416-20	PLANE BEARING, CRANKSHAFT 1 COUSSINET DE VILEBREQUIN 1	6	6	6	UR BLUE UR BLUE
5	62Y-11650-20	CONNECTING ROD ASSY BIELLE COMPLETE	2	2	2	
6	62Y-11654-00	.BOLT, CONNECTING ROD .BOULON, BIELLE	2	2	2	
7	62Y-11656-00	PLANE BEARING, CONNECTING ROD ROULEMENT DE BIELLE	4	4	4	UR BROWN UR BROWN
	62Y-11656-10	PLANE BEARING, CONNECTING ROD ROULEMENT DE BIELLE	4	4	4	UR BLACK UR BLACK
	62Y-11656-20	PLANE BEARING, CONNECTING ROD ROULEMENT DE BIELLE	4	4	4	UR BLUE UR BLUE
8	65W-11631-00-96	PISTON (STD) PISTON (STD)	2	2	2	
	65W-11635-00	PISTON (0.25MM O/S) PISTON (0.25MM O/S)	2	2	2	AP AP
	65W-11636-00	PISTON (0.50MM O/S) PISTON (0.50MM O/S)	2	2	2	AP AP
9	68U-11603-00	PISTON RING SET (STD) JEU DE SEGMENTS (STD)	2	2	2	
	68U-11604-00	PISTON RING SET (0.25MM O/S) JEU DE SEGMENTS (0.25MM O/S)	2	2	2	AP AP
	68U-11605-00	PISTON RING SET (0.50MM O/S) JEU DE SEGMENTS (0.50MM O/S)	2	2	2	AP AP
10	62Y-11633-00	PIN, PISTON AXE, PISTON	2	2	2	
11	93450-17129	CIRCLIP CIRCLIP, TYPE S	4	4	4	
12	65W-11665-00	CON-ROD ASSY, BALANCE BIELLE COMPLETE, BALANCE	1	1	1	
13	65W-11642-11	PISTON, BALANCE PISTON, BALANCE	1	1	1	
14	90170-20137	NUT ECROU	1	1	1	



6D51200-C030

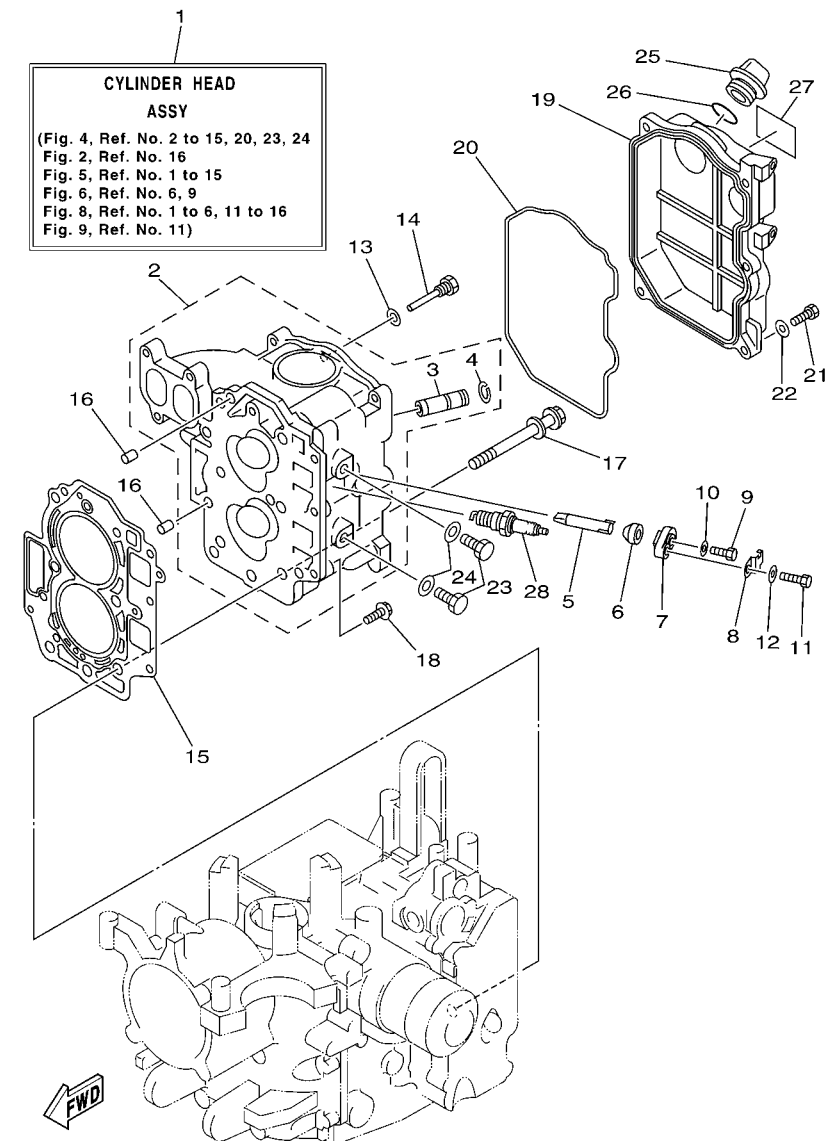

CYLINDER HEAD ASSY
 (Fig. 4, Ref. No. 2 to 15, 20, 23, 24
 Fig. 2, Ref. No. 16
 Fig. 5, Ref. No. 1 to 15
 Fig. 6, Ref. No. 6, 9
 Fig. 8, Ref. No. 1 to 6, 11 to 16
 Fig. 9, Ref. No. 11)

65W8300-G040

*ECM:FOR EMISSION CONTROL MODEL.
 *ECM:POUR MODELE CONTROLE D' EMISSIONS.

FIG. 4 CYLINDER & CRANKCASE 2 CYLINDRE & CARTER 2

REF. NO.	PART NO. N° PIECES	DESCRIPTION DESCRIPTION	MH	U	ET	REMARKS REMARQUES
1	65W-W009A-16-1S	CYLINDER HEAD ASSY CULASSE (ENS.)	1	1	1	
2	65W-11111-20-1S	HEAD, CYLINDER 1 CULASSE	1	1	1	FOR STD FOR STD
	65W-11111-30-1S	HEAD, CYLINDER 1 CULASSE	1	1	1	*ECM-F25A ONLY *ECM-F25A ONLY
3	62Y-11133-30	.GUIDE, VALVE 1 .GUIDE, SOUPAPE 1	4	4	4	
4	93450-09M01	.CIRCLIP .CIRCLIP, TYPE S	4	4	4	
5	62Y-11325-00	ANODE ANODE	2	2	2	
6	66M-11328-00	GROMMET, ANODE PASSE-FIL	2	2	2	
7	66M-11327-00-94	COVER, ANODE COUVERCLE ANODE	2	2	2	
8	66M-12535-00	PLATE PLAQUE	2	2	2	
9	97095-05012	BOLT BOULON	2	2	2	
10	92995-05600	WASHER RONDELLE	2	2	2	
11	97095-06020	BOLT BOULON	2	2	2	
12	92995-06600	WASHER RONDELLE	2	2	2	
13	90430-06014	GASKET JOINT	1	1	1	
14	90109-06M65	BOLT BOULON	1	1	1	
15	65W-11181-30	GASKET, CYLINDER HEAD 1 JOINT, DE CULASSE 1	1	1	1	
16	99530-08012	PIN, DOWEL GOIJON, D'ASSEMBLAGE	2	2	2	
17	90119-09M00	BOLT, WITH WASHER BOULON, AVEC RONDELLE	6	6	6	
18	90119-06MA3	BOLT, WITH WASHER BOULON, AVEC RONDELLE	3	3	3	
19	65W-11191-00-1S	COVER, CYLINDER HEAD 1 COUVERCLE, CULASSE 1	1	1	1	
20	65W-11356-00	SEAL, CYLINDER 2 JOINT, SPY CYLINDRE	1	1	1	
21	97095-06020	BOLT BOULON	5	5	5	
22	92995-06600	WASHER RONDELLE	5	5	5	
23	97095-08014	BOLT BOULON	2	2	2	*ECM-F25A ONLY *ECM-F25A ONLY
24	90430-08143	GASKET JOINT	2	2	2	*ECM-F25A ONLY *ECM-F25A ONLY
25	6G8-15363-00	PLUG, OIL PLOT, HUILE	1	1	1	
26	93210-24M79	O-RING JOINT TORIQUE	1	1	1	

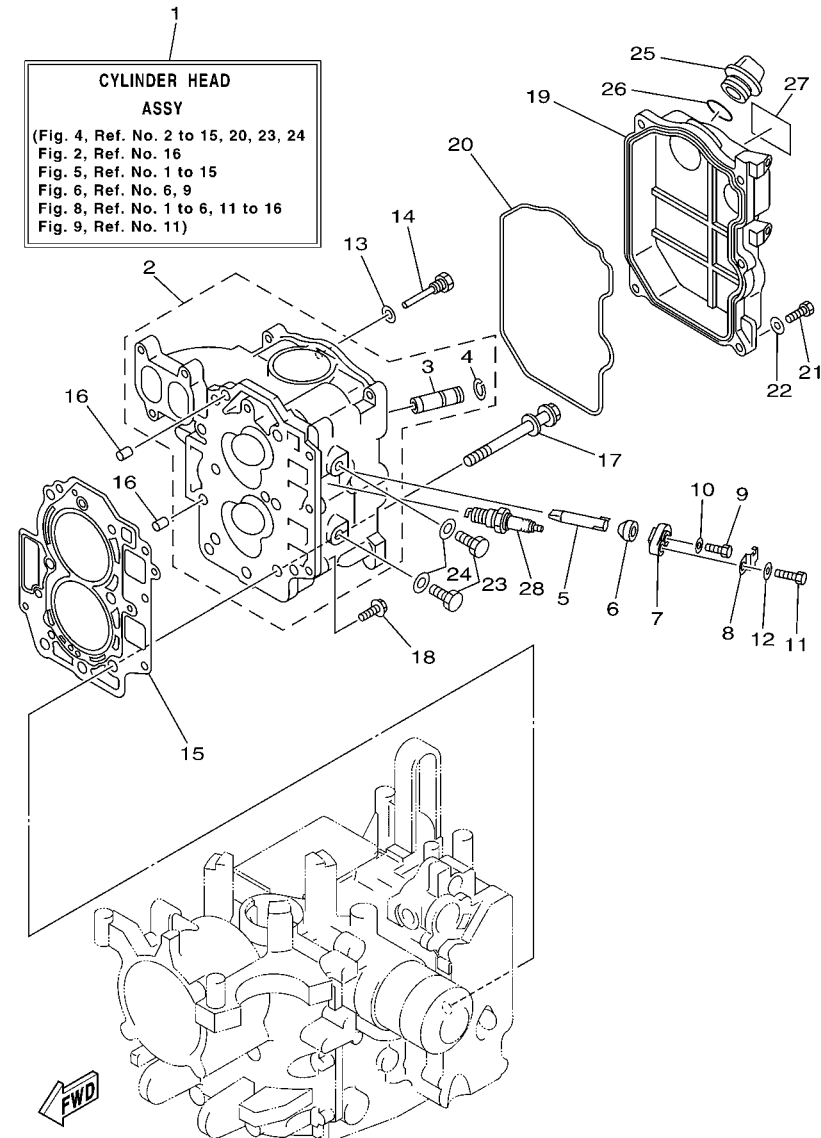

**CYLINDER HEAD
ASSY**
(Fig. 4, Ref. No. 2 to 15, 20, 23, 24
Fig. 2, Ref. No. 16
Fig. 5, Ref. No. 1 to 15
Fig. 6, Ref. No. 6, 9
Fig. 8, Ref. No. 1 to 6, 11 to 16
Fig. 9, Ref. No. 11)

FIG. 4 CYLINDER & CRANKCASE 2 CYLINDRE & CARTER 2

REF. NO.	PART NO. N° PIECES	DESCRIPTION DESCRIPTION	MH	E	ET	REMARKS REMARQUES
27	62Y-12138-60	MARK, CAUTION MAKER	1	1	1	
28	94701-00375	PLUG, SPARK (NGK DPR6EA-9) BOUGIE D'ALLUMAGE(NGK DPR6EA-9)	2	2	2	

*ECM:FOR EMISSION CONTROL MODEL.
*ECM:POUR MODELE CONTROLE D' EMISSIONS.

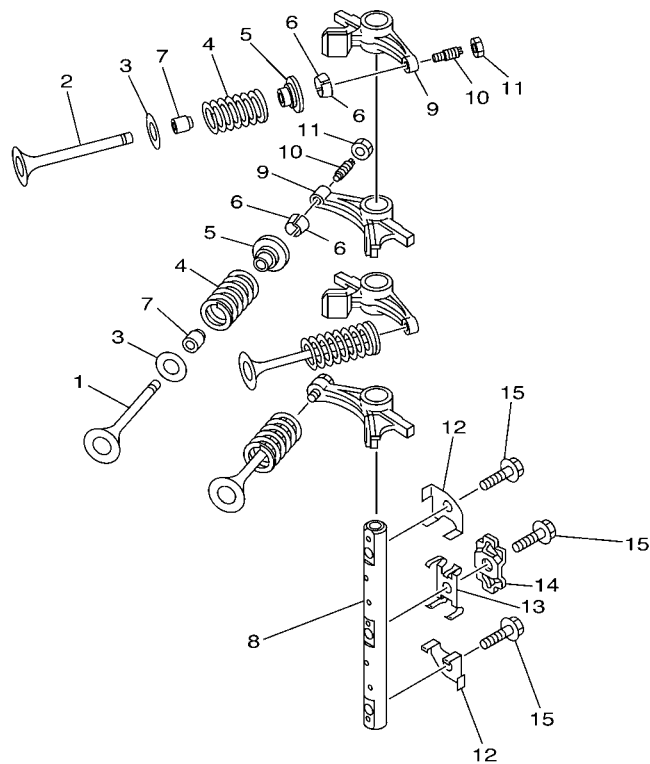

65W1010-2050

FIG. 5 VALVE

SOUPAPE

REF. NO.	PART NO. N° PIECES	DESCRIPTION DESCRIPTION	MH	E	ET	REMARKS REMARQUES
1	67C-12111-00	VALVE, INTAKE SOUPAPE, ADMISSION	2	2	2	
2	62Y-12121-00	VALVE, EXHAUST SOUPAPE, ECHAPPEMENT	2	2	2	
3	62Y-12116-00	SEAT, VALVE SPRING SIEGE, RESSORT DE SOUPAPE	4	4	4	
4	51Y-12114-00	SPRING, VALVE OUTER RESSORT DE SOUPAPE, EXTERNE	4	4	4	
5	30X-12117-00	RETAINER, VALVE SPRING BUTEE DE RESSORT DE SOUPAPE	4	4	4	
6	30X-12118-00	COTTER, VALVE FRAISE, SOUPAPE	8	8	8	
7	51Y-12119-00	SEAL, VALVE STEM JOINT, QUEUE DE SOUPAPE	4	4	4	
8	65W-12146-00	SHAFT, ROCKER AXE, CULBUTEUR	1	1	1	
9	65W-12151-00	ARM, VALVE ROCKER CULBUTEUR	4	4	4	
10	62Y-12159-00	SCREW, VALVE ADJUSTING VIS, REGLAGE DE SOUPAPE	4	4	4	
11	62Y-12158-00	NUT, LOCK CONTRE-ECROU	4	4	4	
12	62Y-12238-00	PLATE, BOLT STOPPER PLAQUE, BUTEE DE BOULON	2	2	2	
13	62Y-12216-00	SPRING RESSORT	1	1	1	
14	62Y-12231-00	GUIDE, STOPPER 1 GUIDE, BUTEE 1	1	1	1	
15	90109-08M63	BOLT BOULON	3	3	3	

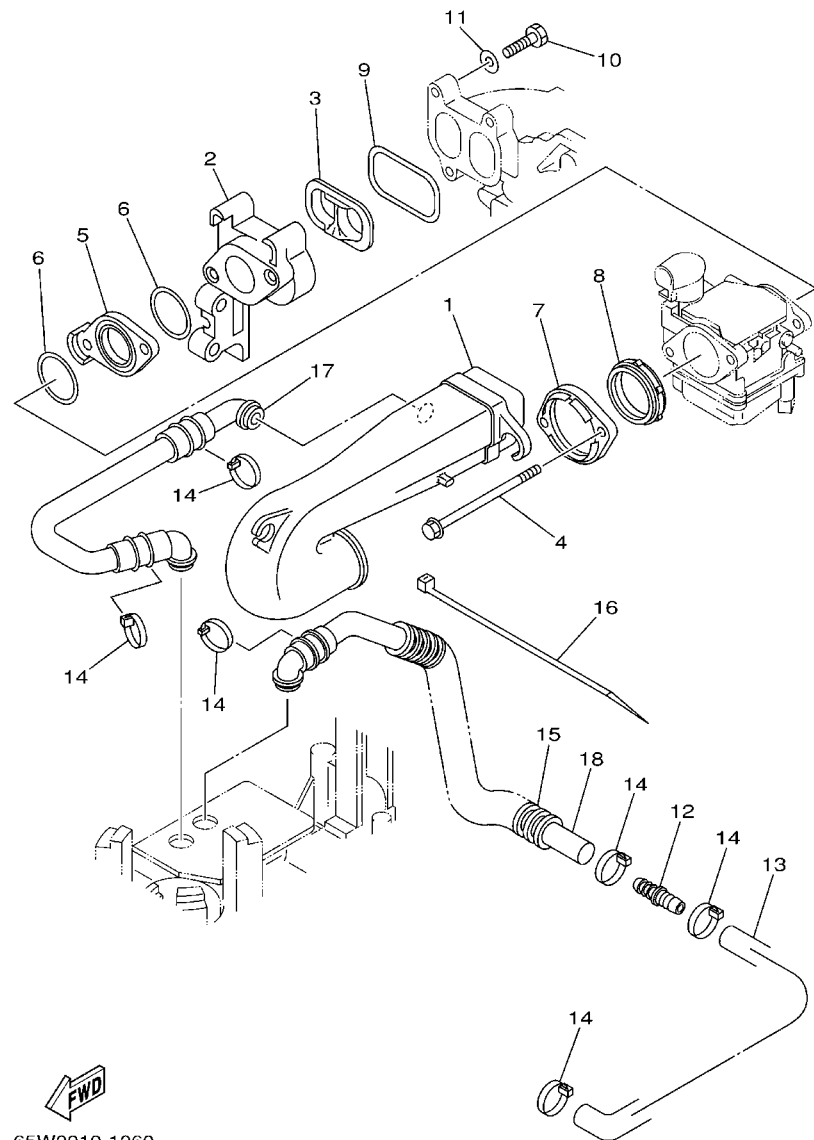

65W0010-1060

FIG. 6 INTAKE

ADMISSION

REF. NO.	PART NO. N° PIECES	DESCRIPTION DESCRIPTION	MH	E	ET	REMARKS REMARQUES
1	65W-14440-00	SILENCER ASSY, INTAKE SIENCIEUX D'ADMISSION	1	1	1	
2	65W-13640-00	MANIFOLD TUBULURE	1	1	1	
3	65W-13323-00	INSERT PIECE RAPPORTEE	1	1	1	
4	65W-14496-00	BOLT BOULON	2	2	2	
5	65W-14271-00	INSULATOR ISOLATEUR	1	1	1	F25A F25A
	65P-14271-00	INSULATOR ISOLATEUR			1	F20A F20A
6	65W-14198-00	GASKET JOINT	2	2	2	
7	65W-14262-00	FLANGE COLLERETTE	1	1	1	
8	65W-14457-10	SEAL JOINT	1	1	1	
9	65W-13645-00	GASKET, MANIFOLD 1 JOINT, TUBULURE 1	1	1	1	
10	97095-06025	BOLT BOULON	3	3	3	
11	92995-06600	WASHER RONDELLE	3	3	3	
12	65W-24377-00	PIPE, JOINT 2 DURITE RACCORDEMENT 2	1	1	1	
13	65W-15397-10	HOSE DURITE	1	1	1	
14	90465-13M36	CLAMP BRIDE	6	6	6	
15	90446-24M54	HOSE (L260) DURITE (L260)	1	1	1	
16	90465-11M52	CLAMP BRIDE	1	1	1	
17	65W-15370-00	BREATHER ASSY RESPIRADERO	1	1	1	
18	65W-15370-10	BREATHER ASSY RESPIRADERO	1	1	1	

FIG. 7 CARBURETOR

CARBURATEUR

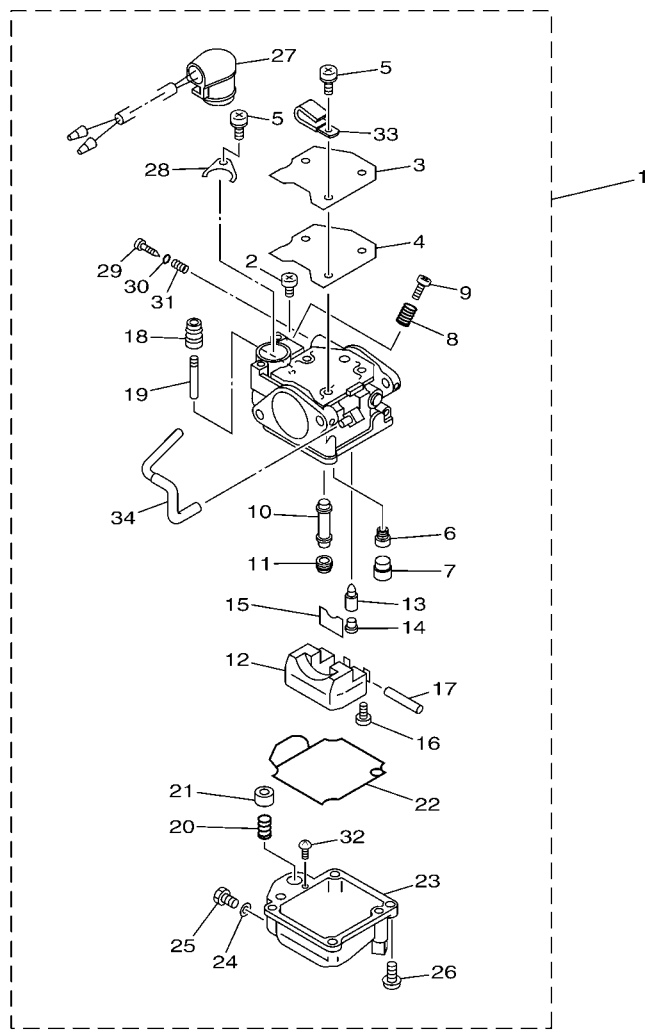

REF. NO.	PART NO. N° PIECES	DESCRIPTION DESCRIPTION	MH	E	ET	REMARKS REMARQUES
1	65W-14901-90	CARBURETOR ASSY 1 CARBURATEUR 1 COMPLET		1	1	F25A-EU1 SPEC F25A-EU1 SPEC
	65W-14901-81	CARBURETOR ASSY 1 CARBURATEUR 1 COMPLET		1		F25A-EU1 SPEC F25A-EU1 SPEC
	65W-14901-70	CARBURETOR ASSY 1 CARBURATEUR 1 COMPLET			1	F20A F20A
	65W-14901-31	CARBURETOR ASSY 1 CARBURATEUR 1 COMPLET		1	1	*ECM-F25A ONLY *ECM-F25A ONLY
2	98580-04006	.SCREW, PAN HEAD .VIS	1	1	1	
3	65W-14572-00	.PLATE .PLAQUE	1	1	1	
4	65W-14126-10	.GASKET .JOINT	1	1	1	
5	97803-04010	.SCREW, PAN HEAD .VIS, CRUCIFORME	4	4	4	
6	676-14948-05	.JET (#45) .GICLEUR (#45)	1	1	1	
	65W-14948-07	.JET (#50) .GICLEUR (#50)	1	1	1	65W-14901-31 65W-14901-31
7	679-14966-00	.RUBBER CAP .CAOUTCHOUC CASQUILLO	1	1	1	
8	90501-10326	.SPRING, COMPRESSION .RESSORT, COMPRESSION	1	1	1	
9	63V-14523-00	.SCREW, STOP .VIS, BUTEE	1	1	1	
10	65W-14947-90	.JET, NEEDLE .GICLEUR DE STARTER	1	1	1	65W-14901-81/90 65W-14901-81/90
	65W-14947-00	.JET, NEEDLE .GICLEUR DE STARTER			1	65W-14901-70 65W-14901-70
	65W-14947-20	.JET, NEEDLE .GICLEUR DE STARTER	1	1	1	65W-14901-31 65W-14901-31
11	65W-14943-78	.JET, MAIN (#108) .GICLEUR, PRINCIPAL (#108)	1	1	1	65W-14901-81/90 65W-14901-81/90
	65W-14943-79	.JET, MAIN (#108) .GICLEUR, PRINCIPAL (#108)			1	65W-14901-70 65W-14901-70
	65W-14943-28	.JET, MAIN (#105) .GICLEUR, PRINCIPAL (#105)	1	1	1	65W-14901-31 65W-14901-31
12	63V-14985-00	.FLOAT .FLOTTEUR	1	1	1	
13	6G1-14546-01	.VALVE, NEEDLE .POINTEAU	1	1	1	
14	676-14186-00	.PIN, FLOAT .AXE, FLOTTEUR	1	1	1	
15	663-14159-00	.CLIP .JONC	1	1	1	
16	98580-04008	.SCREW, PAN HEAD .VIS	1	1	1	
17	6H4-14548-00	.PIN, FLOAT ARM .AXE, BRAS DE FLOTTEUR	1	1	1	
18	65W-14373-01	.COVER, PLUNGER CAP .COUVERCLE DE PLONGEUR	1	1	1	
19	65W-14379-00	.ROD, STARTER .TRINGLE, STARTER	1	1	1	

FWD
65W5300-E070

*ECM:FOR EMISSION CONTROL MODEL.
*ECM:POUR MODELE CONTROLE D' EMISSIONS.

FIG. 7 CARBURETOR

CARBURATEUR

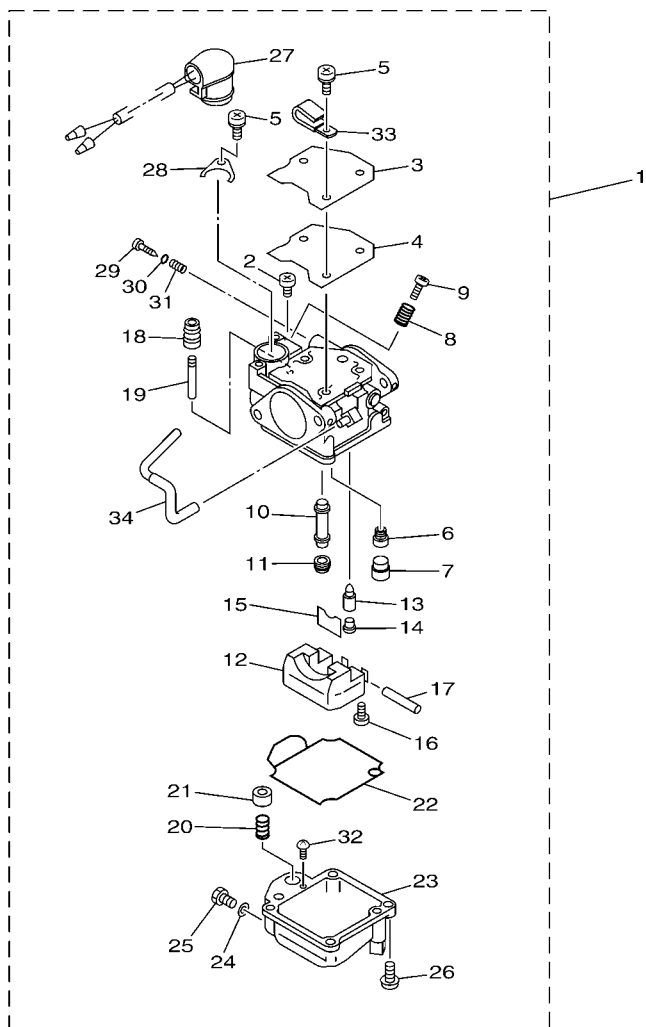

65W5300-E070

*ECM:FOR EMISSION CONTROL MODEL.
 *ECM:POUR MODELE CONTROLE D' EMISSIONS.

REF. NO.	PART NO. N° PIECES	DESCRIPTION DESCRIPTION	MH	E	ET	REMARKS REMARQUES
20	65W-14335-00	.SPRING, PLUNGER .RESSORT, PLONGEUR	1	1	1	
21	65W-14371-00	.PLUNGER, STARTER .PLONGEUR, STARTER	1	1	1	
22	65W-14384-00	.GASKET, FLOAT CHAMBER .JOINT, CUVE DE FLOTTEUR	1	1	1	
23	65W-14980-00	.BODY, FLOAT CHAMBER .CORPS, CUVE DE FLOTTEUR	1	1	1	65W-14901-70/90 65W-14901-70/90
	65W-14980-20	.BODY, FLOAT CHAMBER .CORPS, CUVE DE FLOTTEUR	1	1	1	65W-14901-31/81 65W-14901-31/81
24	65W-14398-00	.GASKET .JOINT	1	1	1	
25	65W-14992-00	.SCREW, DRAIN .BOUCHON, PURGE	1	1	1	
26	97980-04114	.SCREW, WITH WASHER .VIS, AVEC RONDELLE	4	4	4	
27	65W-14380-00	.PRIME STARTER ASSY .STARTER AUTOMATIQUE	1	1	1	65W-14901-70/90 65W-14901-70/90
	65W-14380-20	.PRIME STARTER ASSY .STARTER AUTOMATIQUE	1	1	1	65W-14901-31/81 65W-14901-31/81
28	65W-14346-00	.PLATE .PLAQUE	1	1	1	
29	67C-14923-00	.SCREW, PILOT .VIS, RALENTI	1	1	1	
	65W-14923-10	.SCREW, PILOT .VIS, RALENTI	1	1	1	65W-14901-31 65W-14901-31
30	67C-14397-00	.O-RING .JOINT TORIQUE	1	1	1	
31	67C-14555-00	.SPRING .RESSORT	1	1	1	
32	67C-14567-00	.SCREW .VIS	1	1	1	
33	67F-14255-00	.PLATE .PLAQUE	1	1	1	EXCEPT *ECM-F25A EXCEPT *ECM-F25A
34	65W-14807-00	.HOSE COMP. .DURITE (ENS.)	1	1	1	EXCEPT *ECM-F25A EXCEPT *ECM-F25A

FIG. 8 OIL PUMP

POMPE A HUILE

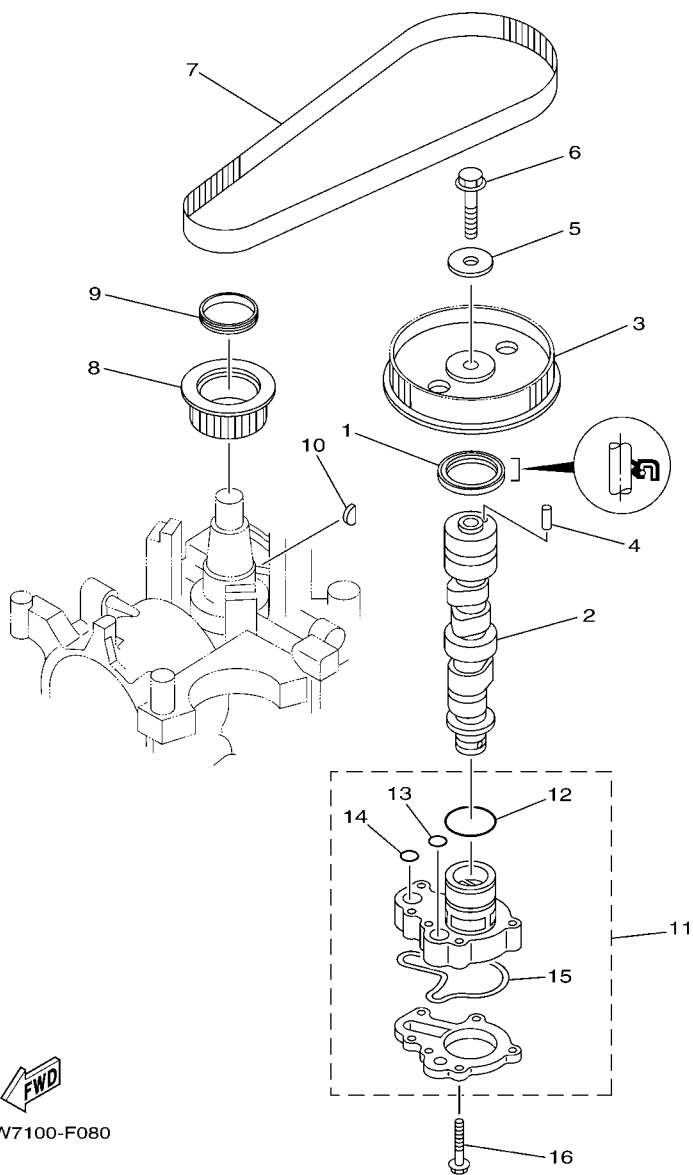

65W7100-F080

REF. NO.	PART NO. N° PIECES	DESCRIPTION DESCRIPTION	MH	E	ET	REMARKS REMARQUES
1	93102-37M40	OIL SEAL JOINT SPY	1	1	1	
2	65W-12171-01	CAMSHAFT 1 ARBRE A CAMES 1		1	1	
	65W-12170-20	CAMSHAFT ASSY 1 ENS ARBRE A CAMES 1	1			
3	65W-11537-01	GEAR, DRIVEN PIGNON SECONDAIRE	1	1	1	
4	93605-14143	PIN, DOWEL AXE	1	1	1	
5	90201-10M06	WASHER, PLATE RONDELLE, PLATE	1	1	1	
6	95895-10040	BOLT, FLANGE BOULON	1	1	1	
7	65W-46241-00	V-BELT COURROIE TRAPEZOIDALE	1	1	1	
8	65W-11536-10	GEAR, DRIVE ENGRENAGE, MENANT	1	1	1	
9	65W-11476-00	SPRING RESSORT	1	1	1	
10	90280-04M06	KEY, WOODRUFF CLAVETTE, DEMI-LUNE	1	1	1	
11	65W-13300-00	OIL PUMP ASSY POMPE A HUILE COMPLETE	1	1	1	
12	93210-33MH2	.O-RING .JOINT TORIQUE	1	1	1	
13	93210-12MG9	.O-RING .JOINT TORIQUE	1	1	1	
14	93210-14515	.O-RING .JOINT TORIQUE	1	1	1	
15	62Y-13142-00	.GASKET .JOINT	1	1	1	
16	90119-06MA5	BOLT, WITH WASHER BOULON, AVEC RONDELLE	4	4	4	

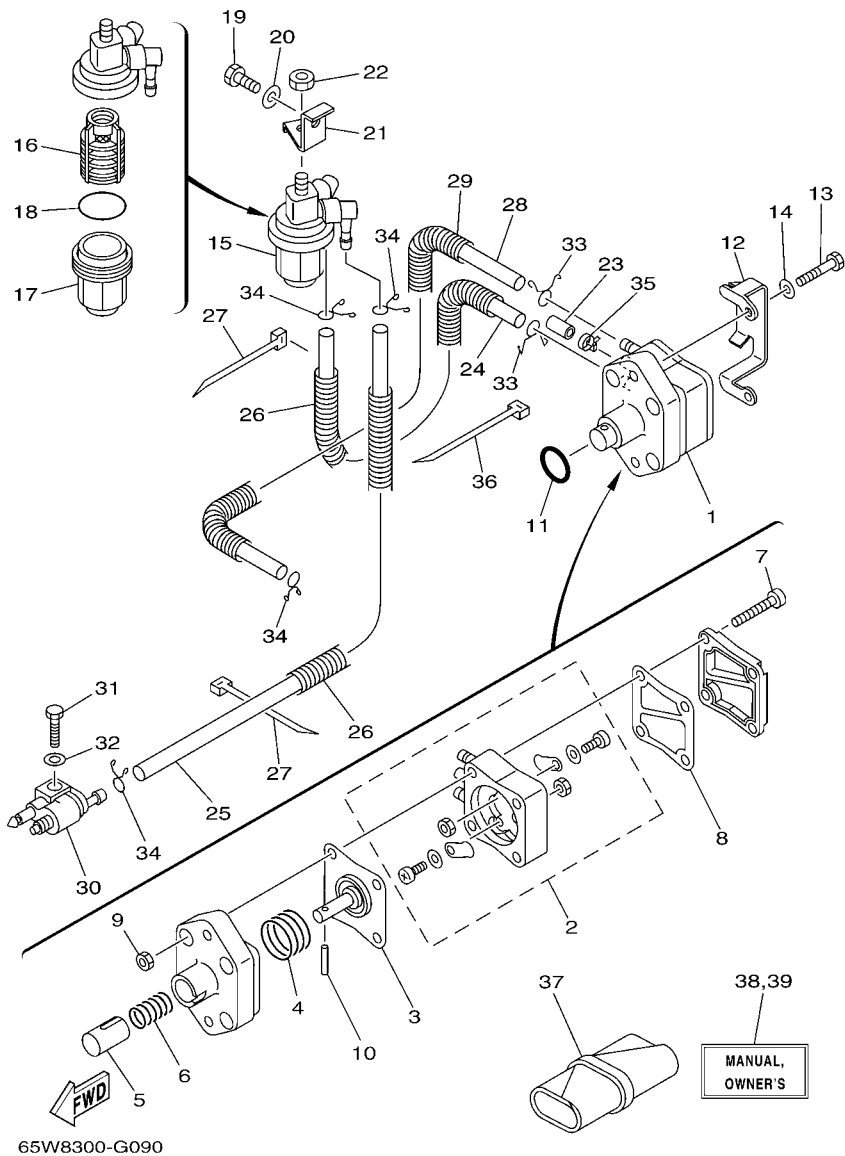

FIG. 9 FUEL

CARBURANT

REF. NO.	PART NO. N° PIECES	DESCRIPTION DESCRIPTION	MH	E	ET	REMARKS REMARQUES
1	62Y-24410-04	FUEL PUMP ASSY POMPE A ESSENCE	1	1	1	
2	62Y-24415-01	.BODY 4 .CORPS 4	1	1	1	
3	62Y-24411-02	.DIAPHRAGM .DIAPHRAGME	1	1	1	
4	62Y-24423-00	.SPRING, DIAPHRAGM .RESSORT, DIAPHRAGME	1	1	1	
5	62Y-13131-01	.PLUNGER .PLONGEUR	1	1	1	
6	62Y-24454-00	.SPRING .RESSORT	1	1	1	
7	62Y-24444-01	.SCREW .VIS	4	4	4	
8	6C5-24471-00	.DIAPHRAGM .DIAPHRAGME	1	1	1	
9	95380-05600	.NUT .ECROU	4	4	4	
10	62Y-24374-01	.PIN .PIN	1	1	1	
11	93210-24M79	O-RING JOINT TORIQUE	1	1	1	
12	65W-24474-10	COVER COUVERCLE	1	1	1	
13	97095-06030	BOLT BOULON	2	2	2	
14	92995-06600	WASHER RONDELLE	2	2	2	
15	61N-24560-00	FILTER ASSY ENS FILTRE	1	1	1	
16	61N-24563-00	.ELEMENT, FILTER .ELEMENT, FILTRE	1	1	1	
17	61N-24521-00	.CUP, FILTER .CUVETTE, FILTRE	1	1	1	
18	93210-32738	.O-RING JOINT TORIQUE	1	1	1	
19	97095-08014	BOLT BOULON	1	1	1	
20	92995-08600	WASHER RONDELLE	1	1	1	
21	6D5-24566-00	BRACKET, FILTER SUPPORT, FILTRE	1	1	1	
22	95380-08600	NUT ECROU	1	1	1	
23	65W-24481-00	PLUG COUVERCLE	1	1	1	
24	90445-10MG6	HOSE (L180) DURITE (L180)	1	1	1	
25	90445-10M34	HOSE (L550) DURITE (L550)	1	1	1	
26	90446-14M12	HOSE DURITE	2	2	2	
27	90465-11M10	CLAMP BRIDE	2	2	2	

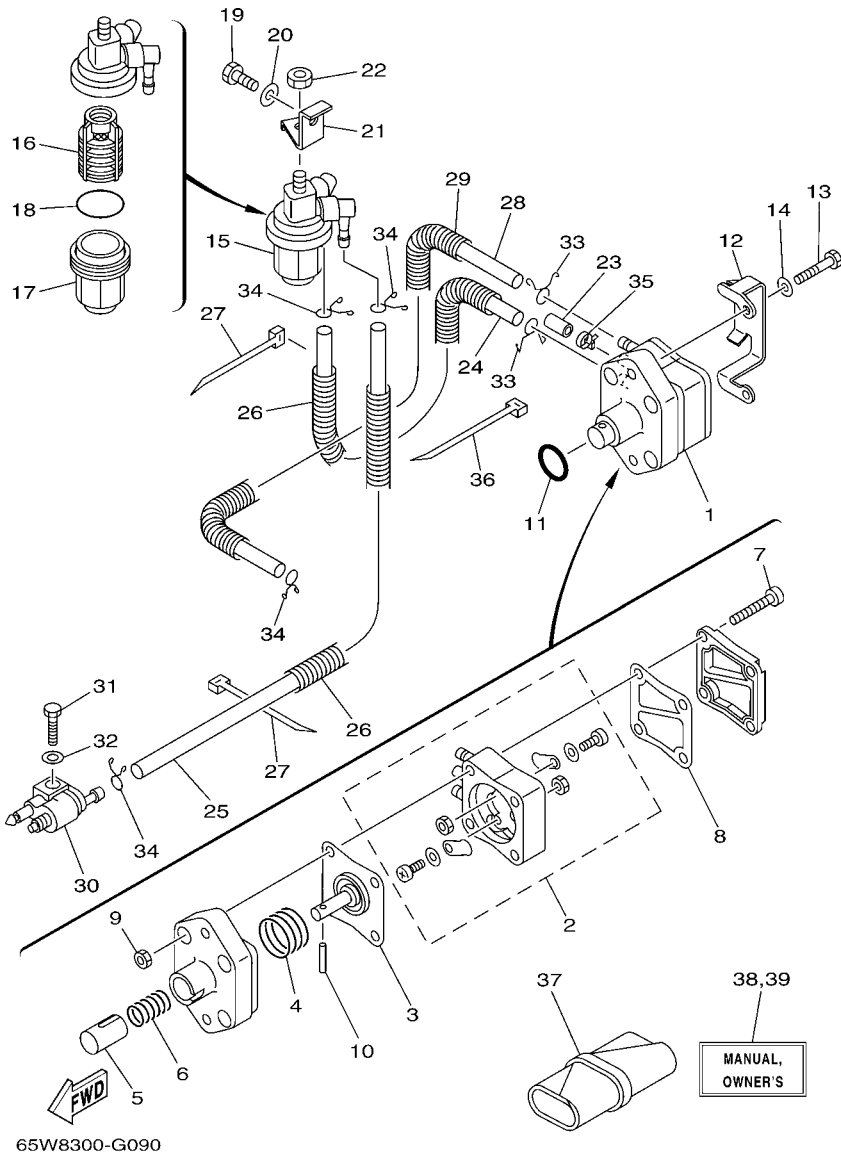

FIG. 9 FUEL

CARBURANT

REF. NO.	PART NO. N° PIECES	DESCRIPTION DESCRIPTION	MH	E	ET	REMARKS REMARQUES
28	90445-10MG7	HOSE (L350) DURITE (L350)	1	1	1	
29	90446-14M51	HOSE DURITE	1	1	1	
30	6G1-24304-02	FUEL PIPE JOINT COMP. 1 DURITE RACCORDEMT. A ESSENCE	1	1	1	
31	97095-06025	BOLT BOULON	1	1	1	
32	92995-06600	WASHER RONDELLE	1	1	1	
33	90467-10M04	CLIP JONC	2	2	2	
34	90467-09M17	CLIP JONC	4	4	4	
35	90465-11M10	CLAMP BRIDE	1	1	1	
36	90465-13M18	CLAMP BRIDE	1	1	1	
37	62Y-28100-00	TOOL KIT TROUSSE A OUTILS	1	1	1	
38	65W-28199-7D-E0	MANUAL,OWNER'S MANUEL D'UTILISATION	1	1	1	UR (E) UR (E)
	65W-28199-7D-F0	MANUAL,OWNER'S MANUEL D'UTILISATION	1	1	1	UR (F) UR (F)
	65W-28199-7D-S0	MANUAL,OWNER'S MANUEL D'UTILISATION	1	1	1	UR (ES) UR (ES)
	65W-28199-7D-G0	MANUAL,OWNER'S MANUEL D'UTILISATION	1	1	1	UR (D) UR (D)
	65W-28199-7D-D0	MANUAL,OWNER'S MANUEL D'UTILISATION	1	1	1	UR (NL) UR (NL)
	65W-28199-7D-H0	MANUAL,OWNER'S MANUEL D'UTILISATION	1	1	1	UR (I) UR (I)
39	65W-28199-8E-K0	MANUAL,OWNER'S MANUEL D'UTILISATION	1	1	1	UR (DK) UR (DK)
	65W-28199-8E-R0	MANUAL,OWNER'S MANUEL D'UTILISATION	1	1	1	UR (GR) UR (GR)
	65W-28199-8E-P0	MANUAL,OWNER'S MANUEL D'UTILISATION	1	1	1	UR (P) UR (P)
	65W-28199-8E-N0	MANUAL,OWNER'S MANUEL D'UTILISATION	1	1	1	UR (N) UR (N)
	65W-28199-8E-M0	MANUAL,OWNER'S MANUEL D'UTILISATION	1	1	1	UR (S) UR (S)
	65W-28199-8E-L0	MANUAL,OWNER'S MANUEL D'UTILISATION	1	1	1	UR (SF) UR (SF)

FIG. 10 STARTER

DEMARREUR

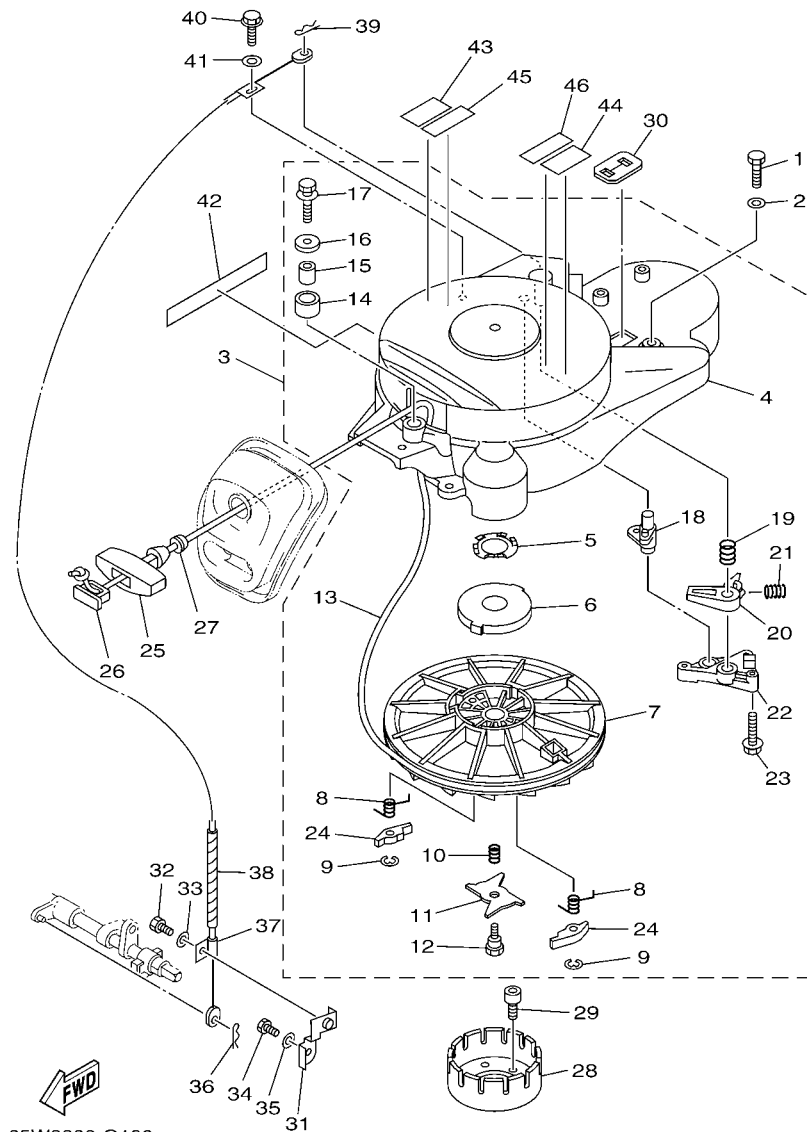

65W8300-G100

*1: CUT FROM 50M ROLLS,PART NO.90890-44373,CUTTING LENGTH 1.7M

*1:A PRELEVER SUR BOBINE 50M ,REFERENCE 90890-44373, LONGUEUR DE COUPE 1.7M

REF. NO.	PART NO. N° PIECES	DESCRIPTION DESCRIPTION	MH	E	ET	REMARKS REMARQUES
1	97095-06025	BOLT BOULON	4			
2	92995-06600	WASHER RONDELLE	4			
3	65W-W1571-20	STARTER ASSY DEMARREUR COMPLET	1			
4	65W-15711-20	.CASE, STARTER .CARTER DE DEMARREUR	1			
5	65W-15732-00	.WASHER, WAVE 1 .RONDELLE ONDULEE 1	1			
6	65W-15713-00	.SPRING, STARTER .RESSORT DE DEMARREUR	1			
7	65W-15714-01	.DRUM, SHEAVE .TAMBOUR, POULIE	1			
8	65W-15734-00	.SPRING, RETURN .RESSORT, RAPPEL	2			
9	65W-15744-00	.CIRCLIP .CIRCLIP	2			
10	65W-15715-00	.SPRING, FRICTION .RESSORT, PLAQUE D'ENTRAINEM	1			
11	65W-15716-00	.PLATE, DRIVE .PLAQUE, ENTRAINEMENT	1			
12	65W-15793-00	.SCREW .VIS	1			
13	*	.WIRE, STARTER (D:5MM, 1.7M) .CABLE DE DEMARREUR(D:5MM,1.7M)	1			*1 *1
14	65W-15752-00	.ROLLER, WIRE .GALET, CABLE	1			
15	65W-15753-00	.BUSH .CHARBON	1			
16	65W-15791-00	.WASHER, LOCK .RONDELLE-FREIN	1			
17	65W-15481-00	.BOLT 1 BOULON 1	1			
18	65W-15735-01	.GUIDE, CAM .COULISSEAU	1			
19	65W-15767-01	.SPRING .RESSORT	1			
20	65W-15794-00	.STOPPER .BUTEE	1			
21	65W-15784-00	.SPRING, RETURN .RESSORT, RAPPEL	1			
22	65W-15414-00	.COVER 1 .COUVERCLE 1	1			
23	65W-15768-00	.BOLT BOULON	3			
24	65W-15741-10	.PAWL, DRIVE .CLIQUET, ENTRAINEMENT	2			
25	689-15755-01	HANDLE, STARTER POIGNEE, DE DEMARREUR	1			
26	6F5-15779-02	COVER COUVERCLE	1			
27	6A0-15789-00	DAMPER AMORTISSEUR	1			

FIG. 10 STARTER

DEMARREUR

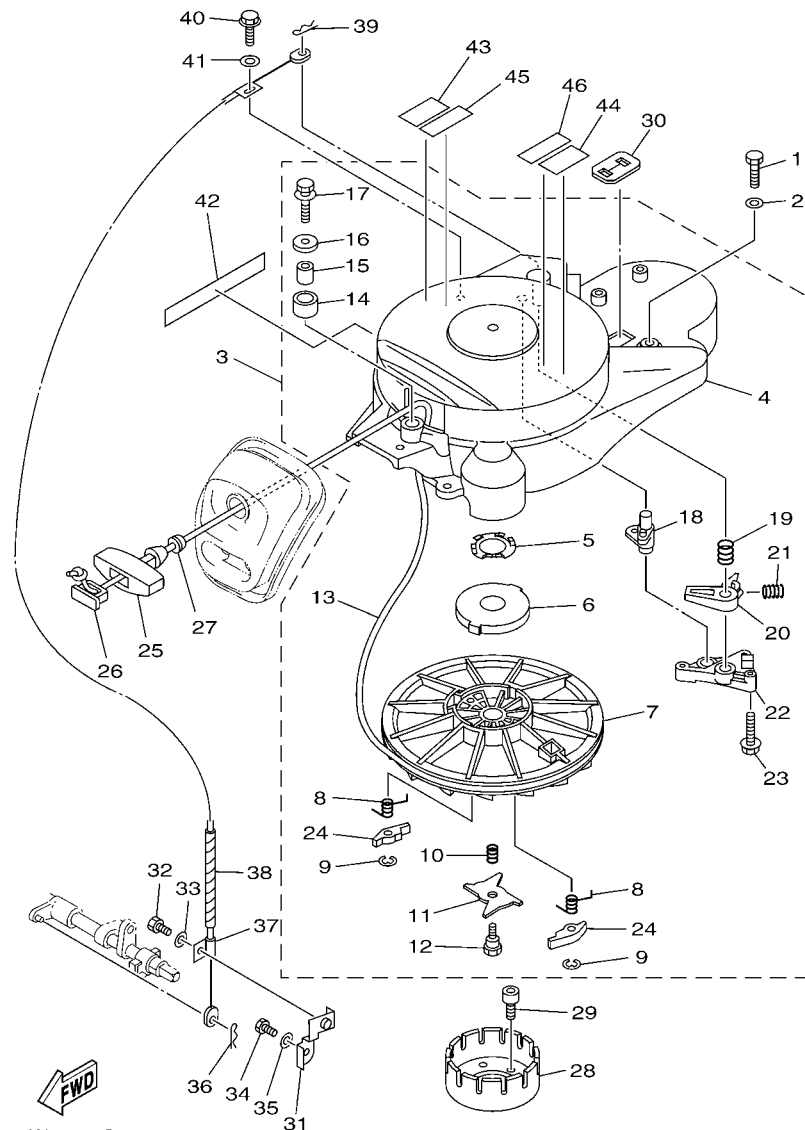

65W8300-G100

*1: CUT FROM 50M ROLLS,PART NO.90890-44373,CUTTING LENGTH 1.7M

*1:A PRELEVER SUR BOBINE 50M ,REFERENCE 90890-44373, LONGUEUR DE COUPE 1.7M

REF. NO.	PART NO. N° PIECES	DESCRIPTION DESCRIPTION	MH	E	ET	REMARKS REMARQUES
28	65W-15723-10	PULLEY, STARTER POULIE DE DEMARREUR	1			
29	90110-08M03	BOLT, HEXAGON SOCKET HEAD BOULON, TETE HEXAGONALE CREUSE	3			
30	65W-81639-10	PLATE, ARMATURE FITTING PLAQUE, FIXATION D'INDUIT	1			
31	65W-15774-00	STAY 4 SUPPORT 4	1			
32	97095-06012	BOLT BOULON	1			
33	92995-06600	WASHER RONDELLE	1			
34	97095-06012	BOLT BOULON	1			
35	92995-06600	WASHER RONDELLE	1			
36	90468-18008	CLIP JONC	1			
37	65W-15770-20	CABLE COMP., STARTER STOP CABLE, BUTEE DE DEMAR	1			
38	90446-06M90	HOSE (L120) DURITE (L120)	1			
39	90468-10005	CLIP JONC	1			
40	65W-15482-20	BOLT 2 BOULON 2	1			
41	65W-15726-00	WASHER, FLAT RONDELLE, PLATE	1			
42	65W-13437-62	MARK, CAUTION MAKER	1			
43	6AH-81995-40	LABEL, WARNING ETIQUETTE, AVERTISSEMENT	1			
44	6AH-81995-50	LABEL, WARNING ETIQUETTE, AVERTISSEMENT	1			
45	6AH-81994-40	LABEL, SAFETY ETIQUETTE, SECURITE	1			
46	6AH-81994-50	LABEL, SAFETY ETIQUETTE, SECURITE	1			

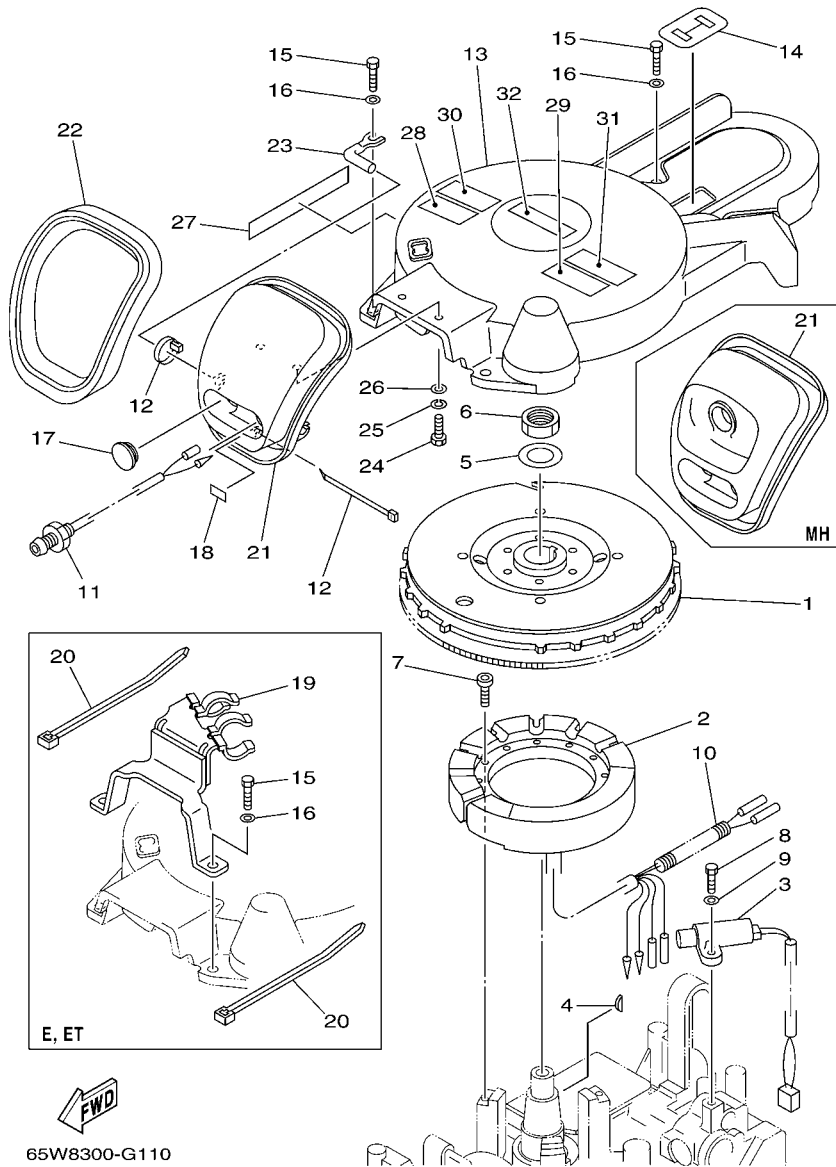

FIG. 11 GENERATOR

GENERATRICE

REF. NO.	PART NO. N° PIECES	DESCRIPTION DESCRIPTION	MH	E	ET	REMARKS REMARQUES
1	65W-85550-01	ROTOR ASSY		1	1	
		ROTOR CPLT				
	65W-85550-11	ROTOR ASSY	1			
		ROTOR CPLT				
2	65W-85510-10	STATOR ASSY		1	1	
		STATOR CPLT				
	65W-85510-00	STATOR ASSY	1			
		STATOR CPLT				
3	65W-85580-00	COIL, PULSER	1	1	1	
		BOBINE, PULSEUR				
4	65W-11545-00	KEY, WOODRUFF	1	1	1	
		CLAVETTE, DEMI-LUNE				
5	90201-21M18	WASHER, PLATE	1	1	1	
		RONDELLE, PLATE				
6	90170-20137	NUT	1	1	1	
		ECROU				
7	91380-05030	BOLT		3	3	
		BOULON				
	91380-05025	BOLT		3		
		BOULON				
8	97095-05016	BOLT	2	2	2	
		BOULON				
9	92995-05600	WASHER	2	2	2	
		RONDELLE				
10	90446-10M82	HOSE (L90)	1	1	1	
		DURITE (L90)				
11	65W-85410-01	EMERGENCY SIGNAL LIGHT ASSY	1	1	1	
		FEU DE DETRESSE				
12	90465-11M10	CLAMP	2	2	2	
		BRIDE				
13	65W-81337-00	COVER, FLYWHEEL		1	1	
		COUVERCLE, VOLANT				
14	65W-81639-00	PLATE, ARMATURE FITTING		1	1	
		PLAQUE, FIXATION D'INDUIT				
15	97095-06025	BOLT	4	4		
		BOULON				
16	92995-06600	WASHER	4	4		
		RONDELLE				
17	6G1-42725-00	GROMMET	1	1		
		PASSE-FIL				
18	65W-84342-00	SEAT, EMBLEM	1	1	1	
		SIEGE, EMBLEME				
19	65W-82594-10	CLAMP		1	1	
		BRIDE				
20	90465-13M18	CLAMP		2	2	
		BRIDE				
21	65W-15758-10	GUIDE, ROPE		1	1	
		GUIDE DE CABLE				
	65W-15758-00	GUIDE, ROPE		1		
		GUIDE DE CABLE				
22	65W-15762-00	SEAL, RUBBER 2	1	1	1	
		JOINT CAOUTCHOUC 2				
23	65W-15771-00	STAY 1	1	1	1	
		SUPPORT 1				

FIG. 11 GENERATOR

GENERATRICE

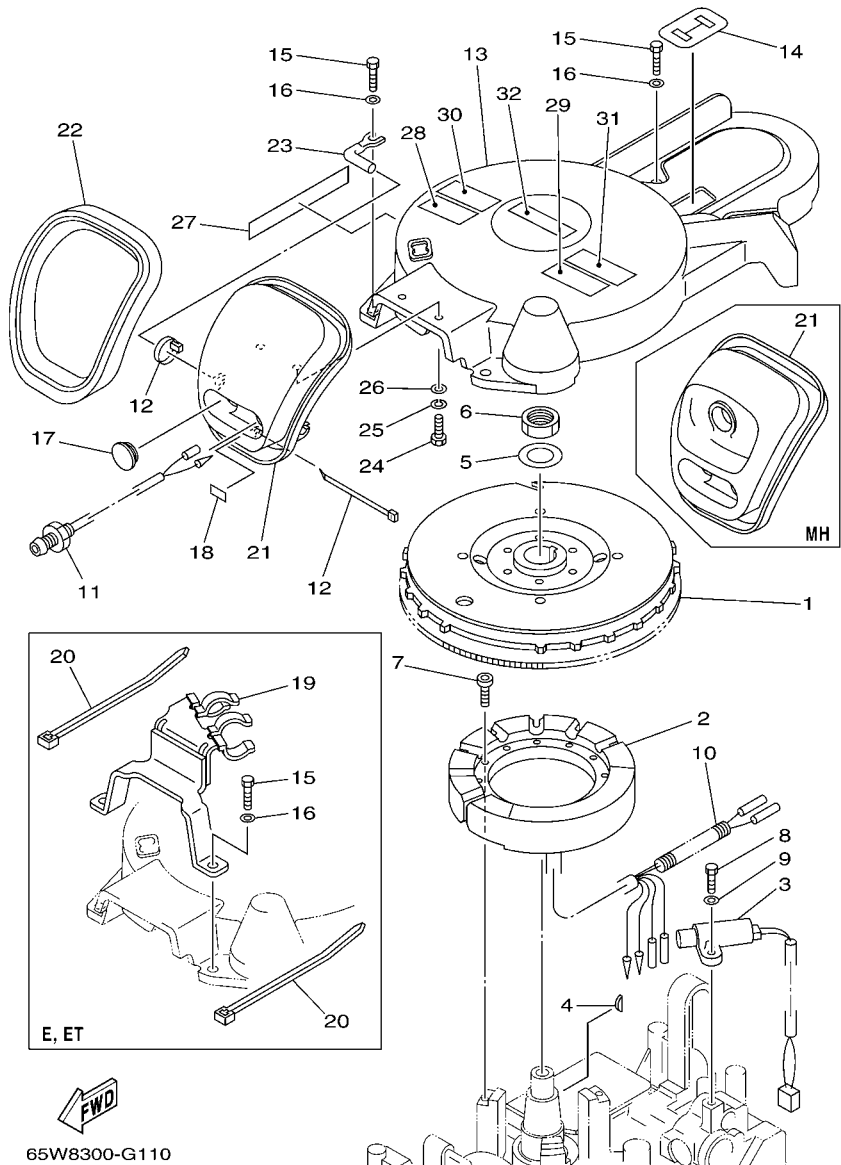

REF. NO.	PART NO. N° PIECES	DESCRIPTION DESCRIPTION	MH	E	ET	REMARKS REMARQUES
24	97095-06020	BOLT BOULON	2	2	2	
25	92995-06100	WASHER, SPRING RONDELLE, GROWER	2	2	2	
26	92995-06600	WASHER RONDELLE	2	2	2	
27	65W-13437-62	MARK, CAUTION MAKER		1	1	
28	6AH-81995-40	LABEL, WARNING ETIQUETTE, AVERTISSEMENT		1	1	
29	6AH-81995-50	LABEL, WARNING ETIQUETTE, AVERTISSEMENT		1	1	
30	6AH-81994-40	LABEL, SAFETY ETIQUETTE, SECURITE		1	1	
31	6AH-81994-50	LABEL, SAFETY ETIQUETTE, SECURITE		1	1	
32	6AG-81996-00	MARK MARQUE		1	1	

FIG. 12 ELECTRICAL 1

PARTIE ELECTRIQUE 1

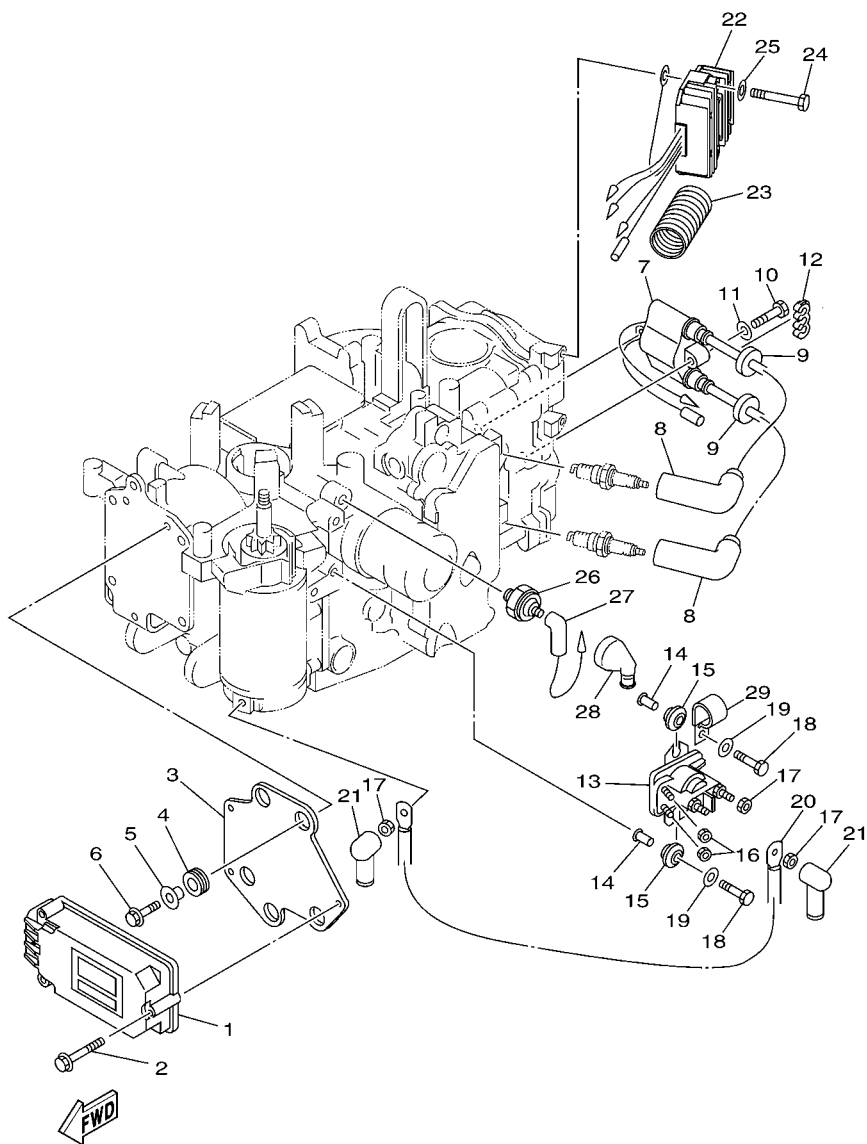

65W3300-C120

REF. NO.	PART NO. N° PIECES	DESCRIPTION DESCRIPTION	MH	E	ET	REMARKS REMARQUES
1	65W-85540-20	C.D.I. UNIT ASSY BLOC C.D.I.	1	1	1	
2	65W-8252V-00	SCREW, SPECIAL VIS, SPECIALE	3	3	3	
3	65W-85542-00	BRACKET SUPPORT	1	1	1	
4	65W-85547-00	DAMPER AMORTISSEUR	3	3	3	
5	65W-86129-20	COLLAR COLLERETTE	3	3	3	
6	65W-8252V-10	SCREW, SPECIAL VIS, SPECIALE	3	3	3	
7	65W-85570-01	IGNITION COIL ASSY BOBINE D'ALLUMAGE (ENS.)	1	1	1	
8	6G8-82370-30	PLUG CAP ASSY ANTIPARASITE	2	2	2	
9	90480-25161	GROMMET PASSE-FIL	2	2	2	
10	97095-06030	BOLT BOULON	2	2	2	
11	92995-06600	WASHER RONDELLE	2	2	2	
12	90464-07M05	CLAMP BRIDE	1	1	1	
13	65W-81941-01	STARTER RELAY ASSY LANCEUR RELAIS (ENS.)	1	1		
14	65W-8191C-00	COLLAR COLLERETTE	2	2		
15	65W-81922-00	GROMMET OUILLET CAOUTCHOUC	2	2		
16	65W-8182A-00	NUT ECROU	2	2		
17	65W-8182B-00	NUT, SPECIAL ECROU, SPECIAL	3	3		
18	97095-06025	BOLT BOULON	2	2		
	97095-06016	BOLT BOULON	1			
19	92995-06600	WASHER RONDELLE	2	2		
	92995-06600	WASHER RONDELLE	1			
20	65W-82117-00	WIRE, LEAD FIL	1	1		
21	6G5-82119-10	COVER, LEAD WIRE GARNITURE, FIL	2	2		
22	65W-81960-10	RECTIFIER & REGULATOR ASSY REDRESSEUR REGULATEUR CPLT	1	1		
23	6K3-83557-00	TUBE TUBE	1	1		
24	97095-06040	BOLT BOULON	2	2		
25	92995-06600	WASHER RONDELLE	2	2		

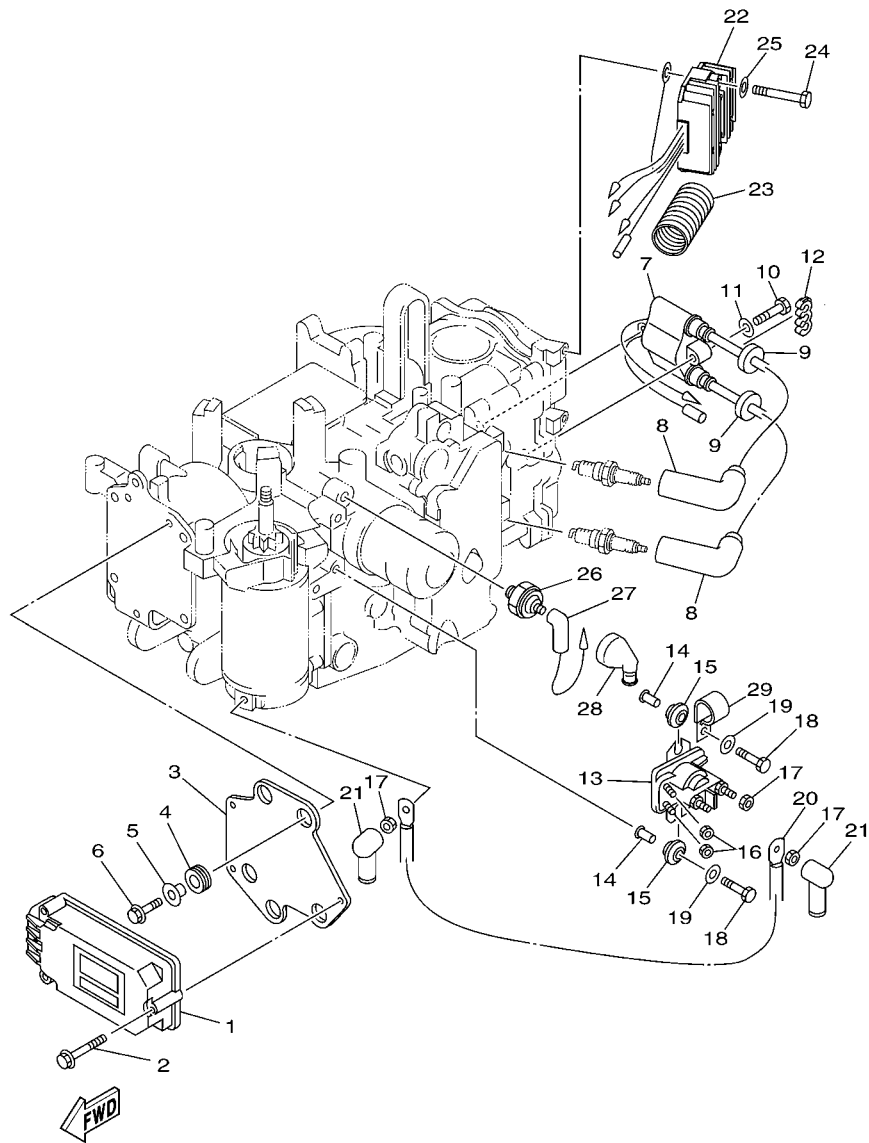

65W3300-C120

FIG. 12 ELECTRICAL 1

PARTIE ELECTRIQUE 1

REF. NO.	PART NO. N° PIECES	DESCRIPTION DESCRIPTION	MH	E	ET	REMARKS REMARQUES
26	65W-82504-00	OIL PRESSURE SWITCH ASSY CONTACTEUR DE PRESSION D'HUILE	1	1	1	
27	65W-82127-00	WIRE, LEAD 2 FIL 2	1	1	1	
28	65W-82532-00	CAP COUVERCLE	1	1	1	
29	65W-8339X-00	CLAMP, CORD COLLIER, CORDON	1	1	1	

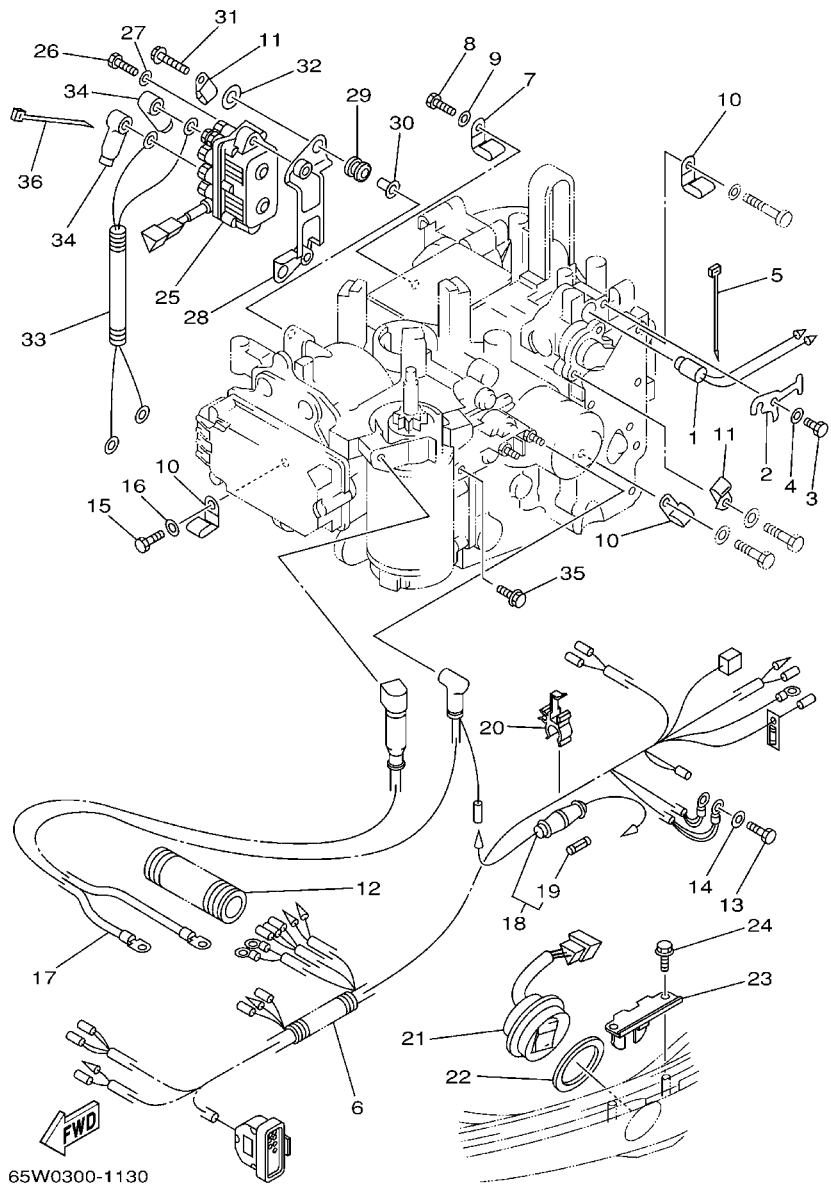

65W0300-1130

FIG. 13 ELECTRICAL 2

PARTIE ELECTRIQUE 2

REF. NO.	PART NO. N° PIECES	DESCRIPTION DESCRIPTION	MH	E	ET	REMARKS REMARQUES
1	65W-85790-00	THERMOSENSOR ASSY SENSITOMETRE	1	1	1	
2	65W-85757-00	RETAINER ARRETOIR	1	1	1	
3	97095-06012	BOLT BOULON	1	1	1	
4	92995-06600	WASHER RONDELLE	1	1	1	
5	90465-11M10	CLAMP BRIDE	1	1	1	
6	65W-82590-10	WIRE HARNESS ASSY (7P) FAISCEAU DE FILS COMPLET (7P)		1		
	65W-82590-30	WIRE HARNESS ASSY (10P) FAISCEAU DE FILS COMPLET (10P)			1	
	65W-82590-40	WIRE HARNESS ASSY FAISCEAU DE FILS COMPLET	1			
7	90465-08M08	CLAMP BRIDE			1	
8	97095-06016	BOLT BOULON			1	
9	92995-06600	WASHER RONDELLE			1	
10	90465-08M08	CLAMP BRIDE	3	3	3	
11	90465-06M88	CLAMP BRIDE		2	2	
	90465-06M88	CLAMP BRIDE	1			
12	6N7-83557-00	TUBE (I.DIA:22MM) TUBE (I.DIA:22MM)	1	1	1	
13	97095-06016	BOLT BOULON	2	2	2	
14	92995-06600	WASHER RONDELLE	2	2	2	
15	97095-05016	BOLT BOULON	1	1	1	
16	92995-05600	WASHER RONDELLE	1	1	1	
17	65W-82105-00	WIRE HARNESS FAISCEAU DE FILS		1	1	
18	6G8-82150-00	FUSE HOLDER ASSY SUPPORT DE FUSIBLE		1	1	
19	663-82151-00	.FUSE (12V-20A) .FUSIBLE (12V-20A)		1	1	
20	6G5-82152-00	HOLDER, FUSE SUPPORT, FUSIBLE		1	1	
21	6H1-82563-10	TRIM & TILT SWITCH ASSY INCLINER ET PARER COMMUTATEUR			1	
22	6E5-82587-00	GASKET JOINT			1	
23	62Y-83614-00	BRACKET SUPPORT			1	
24	90109-06M86	BOLT BOULON			2	

FIG. 14 ELECTRICAL 3

PARTIE ELECTRIQUE 3

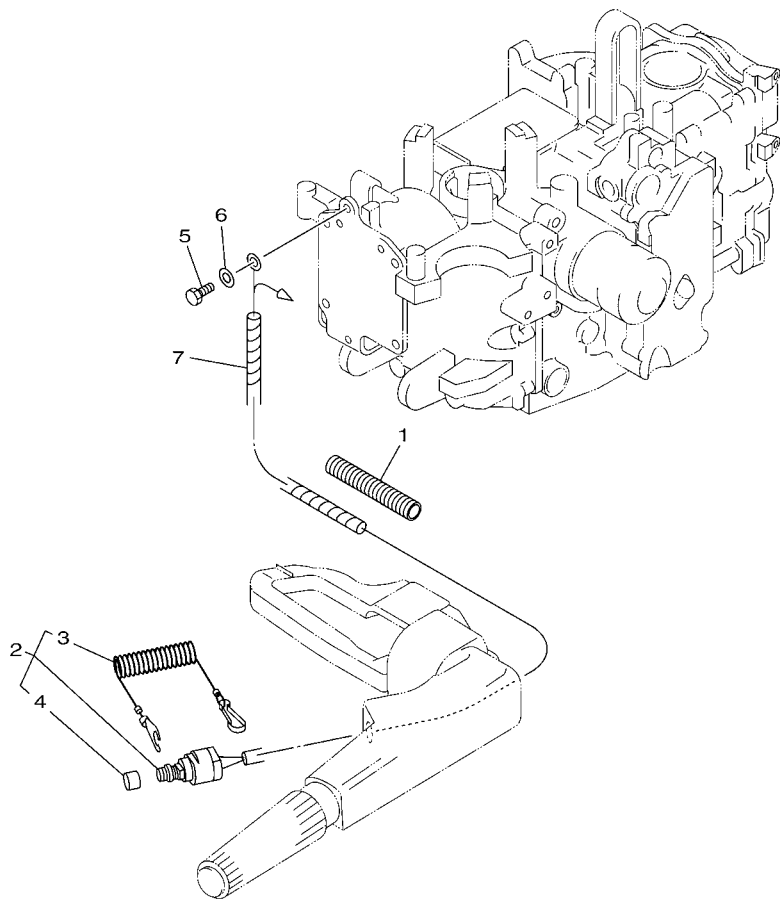



65W4300-D140

REF. NO.	PART NO. N° PIECES	DESCRIPTION DESCRIPTION	MH	E	ET	REMARKS REMARQUES
1	6N7-83557-00	TUBE (I.DIA:22MM) TUBE (I.DIA:22MM)	1			
2	65W-82575-01	ENGINE STOP SWITCH ASSY COUPE CIRCUIT CPLT	1			
3	682-82556-00	.LANYARD, STOP SWITCH .PLAQUETTE	1			
4	689-8257Y-00	.CAP .CHAPEAU	1			
5	97095-06012	BOLT BOULON	1			
6	92995-06600	WASHER RONDELLE	1			
7	90448-03002	HOSE, WITH UNION DURITE, AVEC RACCORD	1			

FIG. 15 STARTING MOTOR

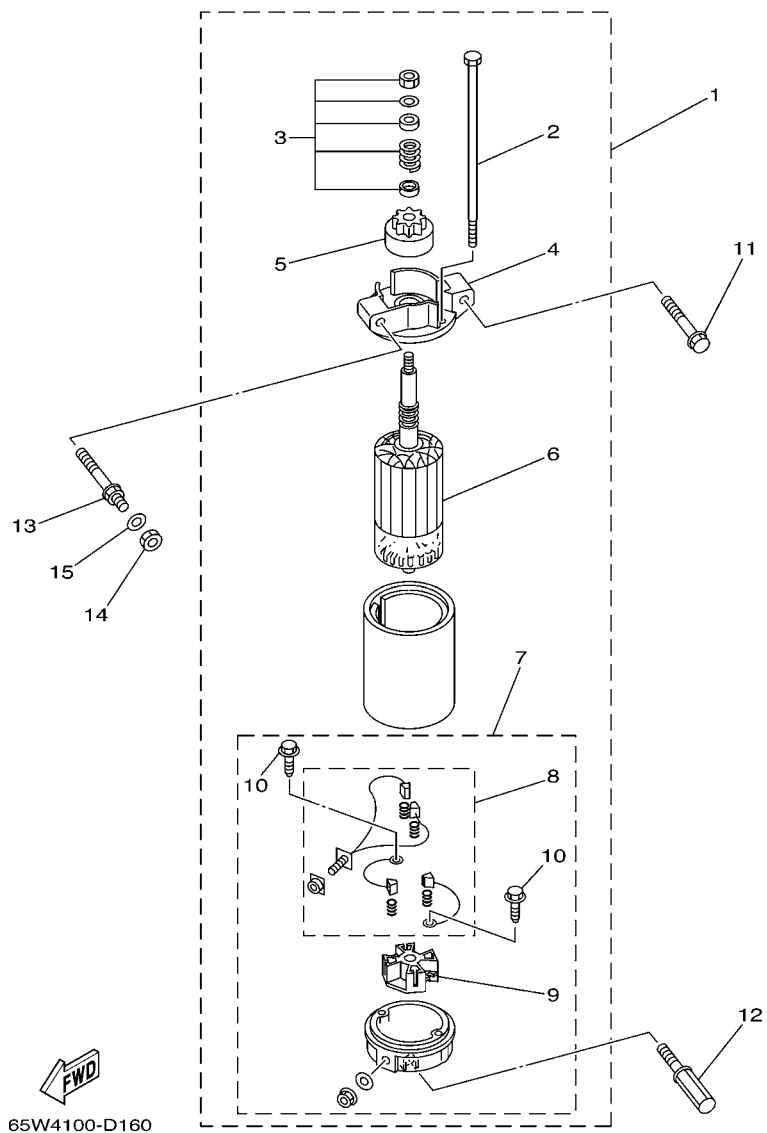
DEMARREUR ELECTRIQUE



65W4100-D160

REF. NO.	PART NO. N° PIECES	DESCRIPTION DESCRIPTION	MH	E	ET	REMARKS REMARQUES
1	65W-81800-03	STARTING MOTOR ASSY DEMARREUR ELECTRIQUE COMPLET		1	1	
2	65W-81826-00	.BOLT .BOULON		2	2	
3	65W-81857-03	.RETAINER .ARRETOIR		1	1	
4	65W-81830-00	.FRONT BRACKET ASSY .SUPPORT AVANT		1	1	
5	65W-81807-00	.GEAR ASSY, STARTING MOTOR .PIGNON, DEMARREUR ELECTRIQUE		1	1	
6	65W-81850-02	.ARMATURE ASSY .INDUIT		1	1	
7	65W-81820-00	.REAR BRACKET ASSY .SUPPORT ARRIERE COMPLET		1	1	
8	65W-81801-00	..BRUSH SET ..CHARBON		1	1	
9	65W-81840-00	..BRUSH HOLDER ASSY ..SUPPORT DE CHARBON		1	1	
10	65W-8182S-00	..SCREW ..VIS		2	2	
11	90119-08M39	BOLT, WITH WASHER BOULON, AVEC RONDELLE		1	1	
12	90109-08M77	BOLT BOULON		1	1	
13	90109-08M78	BOLT BOULON		1	1	
14	95380-08700	NUT ECROU		1	1	
15	92990-08600	WASHER, PLATE RONDELLE, PLATE		2	2	

FIG. 16 BOTTOM COWLING

CAPOT INFERIEUR

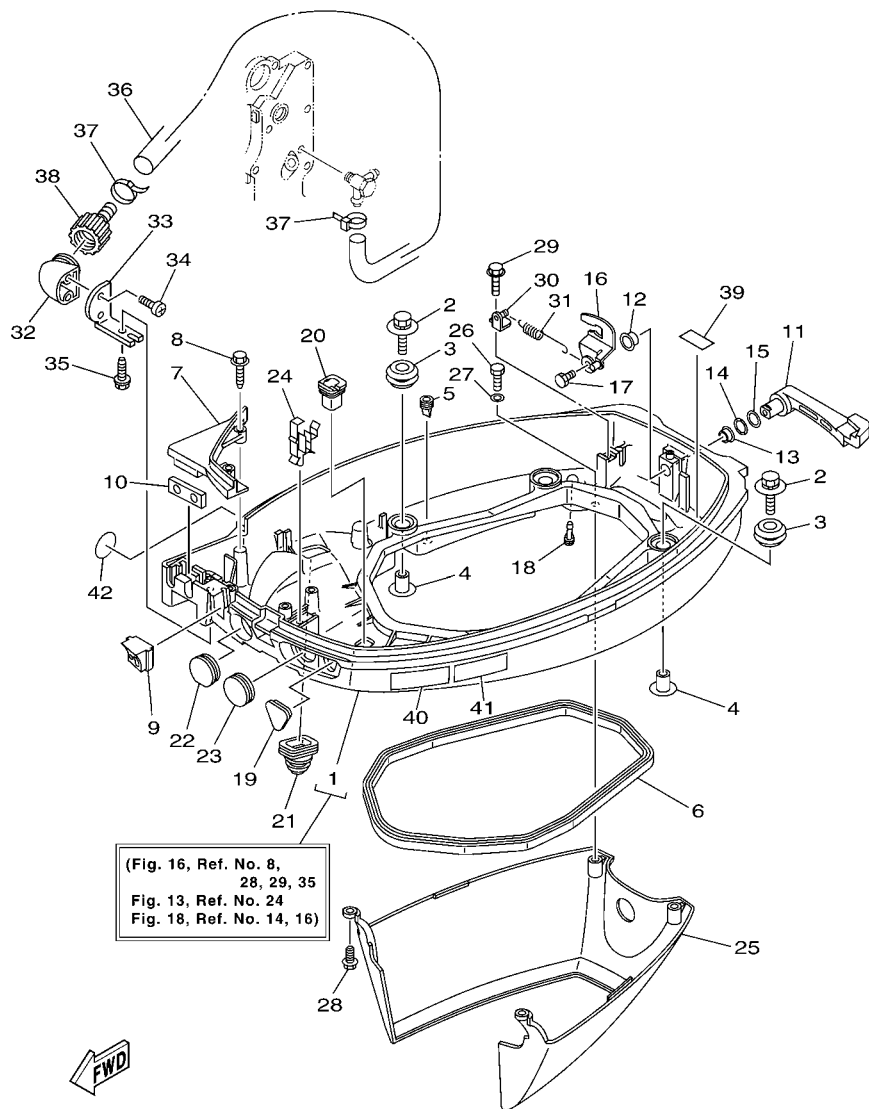

65W8300-G160

REF. NO.	PART NO. N° PIECES	DESCRIPTION DESCRIPTION	MH	E	ET	REMARKS REMARQUES
1	65W-42710-06-4D	BOTTOM COWLING ASSY ENS. EMBASE	1	1		WITH TAPPING BOLT WITH TAPPING BOLT WITH TAPPING BOLT WITH TAPPING BOLT
	65W-42710-16-4D	BOTTOM COWLING ASSY ENS. EMBASE			1	
2	90119-06M08	BOLT, WITH WASHER BOULON, AVEC RONDELLE	4	4	4	
3	90480-09M12	GROMMET PASSE-FIL	4	4	4	
4	90387-06060	COLLAR COLLERETTE	4	4	4	
5	65W-42717-00	RUBBER, SEAL 2 JOINT EN CAOUTCHOUC 2	6	6	6	
6	62Y-42716-00	RUBBER, SEAL 1 JOINT EN CAOUTCHOUC 1	1	1	1	
7	65W-42738-01-4D	PLATE, FITTING ETRIER	1	1	1	
8	90109-06M82	BOLT BOULON	2	2	2	
9	65W-42725-00	GROMMET PASSE-FIL	1			
	65W-42725-21	GROMMET PASSE-FIL		1	1	
10	65W-42727-00	GROMMET PASSE-FIL	1			
	62Y-42727-00	GROMMET PASSE-FIL		1	1	
11	6D5-42815-00-4D	LEVER, CLAMP LEVIER, PRESSE	1	1	1	
12	90386-12M37	BUSH DOUILLE	1	1	1	
13	90386-12MA2	BUSH DOUILLE	1	1	1	
14	90206-12052	WASHER, WAVE RONDELLE, ONDULEE	1	1	1	
15	90201-12M07	WASHER, PLATE RONDELLE, PLATE	1	1	1	
16	6D5-42816-00	LEVER, CLAMP LEVIER, PRESSE	1	1	1	
17	97095-06012	BOLT BOULON	1	1	1	
18	6H3-44391-01	NIPPLE, HOSE RACCORD D'ESSENCE	1	1	1	
19	65W-26326-00	GROMMET RONDELLE CAOUTCHOUC	1			
	65W-26326-10	GROMMET RONDELLE CAOUTCHOUC		1	1	
20	682-42727-00	GROMMET PASSE-FIL	1	1	1	
21	65W-42724-10	GROMMET PASSE-FIL	1	1		FLUSHING KIT FLUSHING KIT FLUSHING KIT FLUSHING KIT
	6H1-42726-21	GROMMET PASSE-FIL			1	
22	6G1-42725-00	GROMMET PASSE-FIL	1	1	1	

FIG. 16 BOTTOM COWLING

CAPOT INFERIEUR

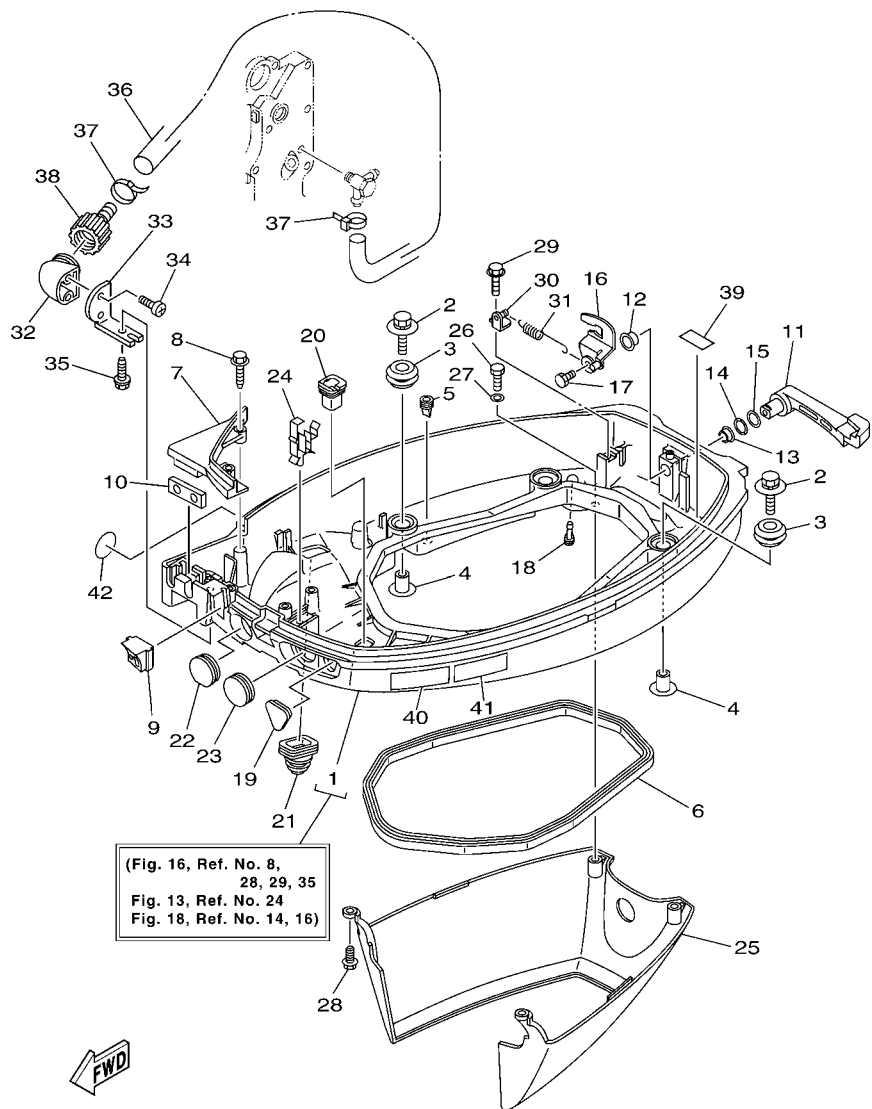

65W8300-G160

REF. NO.	PART NO. N° PIECES	DESCRIPTION DESCRIPTION	MH	E	ET	REMARKS REMARQUES
23	65W-42726-00	GROMMET PASSE-FIL	1			
	65W-42726-10	GROMMET PASSE-FIL		1	1	
24	90465-25M57	CLAMP BRIDE	1	1	1	
25	65W-42741-01	APRON CAPOT LATERAL	1	1	1	
26	97095-06014	BOLT BOULON	2	2	2	
27	92995-06600	WASHER RONDELLE	2	2	2	
28	90109-06M81	BOLT BOULON	2	2	2	
29	90109-06M86	BOLT BOULON	1	1	1	
30	6D5-43144-00	HOOK, SPRING CROCHET	1	1	1	
31	90506-18010	SPRING, TENSION RESSORT, TENSION	1	1	1	
32	68T-12572-00	ADAPTER ADAPTATEUR	1	1	1	FLUSHING KIT
33	69W-12535-00	PLATE PLAQUE	1	1	1	FLUSHING KIT
34	90167-06002	SCREW, TAPPING VIS, TETE FRAISEE	2	2	2	FLUSHING KIT
35	90109-06M86	BOLT BOULON	1	1	1	FLUSHING KIT
36	90445-11M82	HOSE DURITE	1	1	1	FLUSHING KIT
37	90465-11M10	CLAMP BRIDE	2	2	2	FLUSHING KIT
38	6R3-12580-00	JOINT ASSY ARTICULER (ENS.)	1	1	1	FLUSHING KIT
39	62Y-82377-00	LABEL ETIQUETTE	1	1	1	FLUSHING KIT
40	6AH-42794-40	LABEL, WARNING (GENERAL) ETIQUETTE, AVERTISSEMENT	1	1	1	FLUSHING KIT
41	6AH-42794-50	LABEL, WARNING (GENERAL) ETIQUETTE, AVERTISSEMENT	1	1	1	FLUSHING KIT
42	6G8-2415E-00	LABEL, CAUTION ETIQUETTE, RECOMMANDATION	1	1	1	FOR SAV-F25A ONLY FOR SAV-F25A ONLY

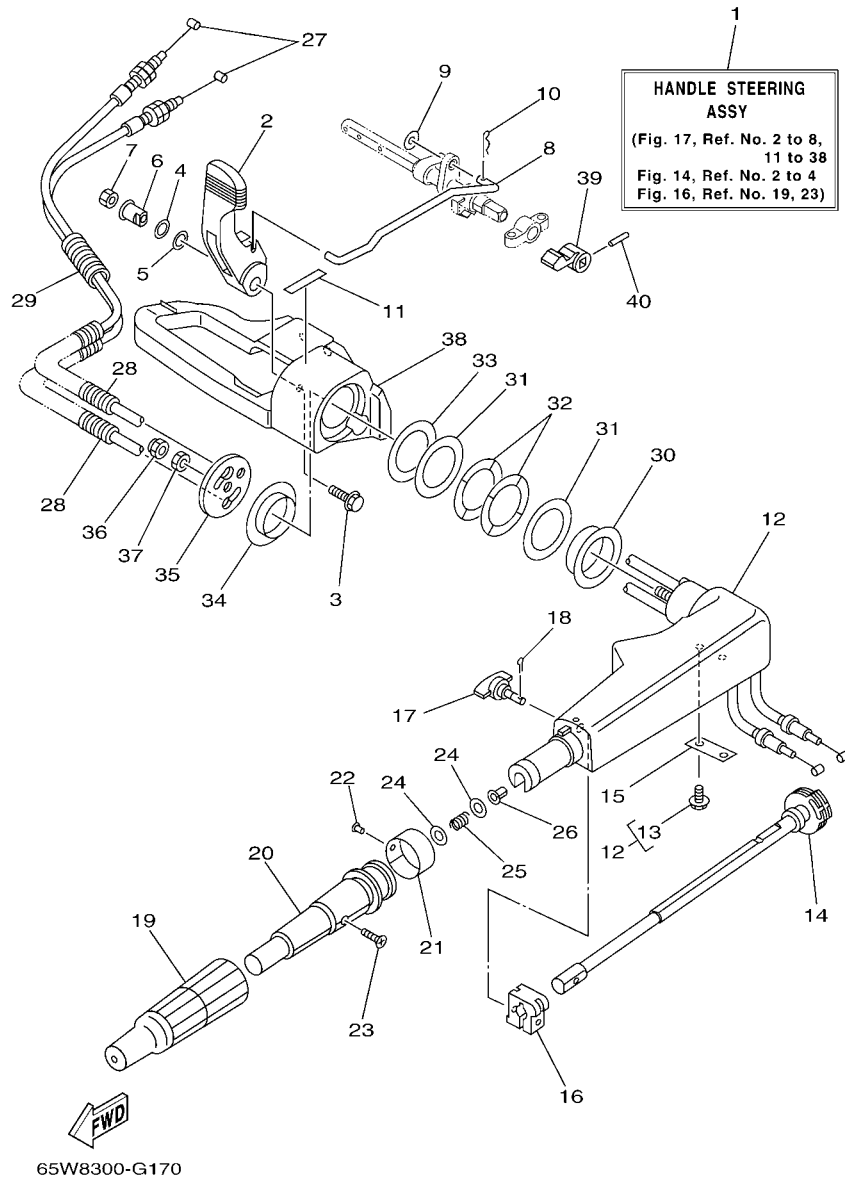

FIG. 17 STEERING

DIRECTION

REF. NO.	PART NO. N° PIECES	DESCRIPTION DESCRIPTION	MH	E	ET	REMARKS REMARQUES
1	65W-W0084-01-4D	HANDLE STEERING ASSY BARRE FRANCHE (ENS.)	1			
2	65W-44111-00	HANDLE, GEAR SHIFT POIGNEE, LEVIER D'EMBRAYAGE	1			
3	90119-06M85	BOLT, WITH WASHER BOULON, AVEC RONDELLE	1			
4	90206-12M00	WASHER, WAVE RONDELLE, ONDULEE	1			
5	90201-12M07	WASHER, PLATE RONDELLE, PLATE	1			
6	65W-42123-00	BOLT, HANDLE JOINT BOULON	1			
7	95380-06600	NUT, HEXAGON ECROU	1			
8	65W-44124-00	LINK, SHIFT ROD BIELLETTTE	1			
9	92990-06200	WASHER, PLAIN RONDELLE, PLATE	1			
10	90468-18008	CLIP JONC	1			
11	6E0-44191-11	INDICATOR, SHIFT ETIQUETTE, EMBRAYAGE	1			
12	65W-42101-01-4D	HANDLE, STEERING POIGNEE	1			
13	90109-06M86	.BOLT .BOULON	2			
14	65W-42138-00	LEVER, THROTTLE LEVIER, ACCELERATEUR	1			
15	65W-42159-00	STAY SUPPORT	1			
16	6G1-42126-00	FRICTION, STEERING HANDLE GRIP CUVETTE, POIGNEE DE DIRECTION	1			
17	65W-42125-00	BOLT, FRICTION ADJUSTING BOULON	1			
18	91490-16010	PIN, COTTER GOUPILLE	1			
19	66M-42177-00	RUBBER, HANDLE CAOUTCHOUC, POIGNEE	1			
20	66M-42119-00	GRIP, STEERING HANDLE POIGNEE, BARRE FRANCHE	1			
21	6J0-42137-00	INDICATOR, THROTTLE INDICATEUR, ACCELERATION	1			
22	90269-02M09	RIVET RIVET	1			
23	90149-05M13	SCREW VIS	1			
24	90201-10M02	WASHER, PLATE RONDELLE, PLATE	2			
25	90501-23215	SPRING, COMPRESSION RESSORT, COMPRESSION	1			
26	90386-08032	BUSH DOUILLE	1			
27	65W-26311-00	CABLE, THROTTLE 1 CABLE 1, ACCELERATEUR	2			

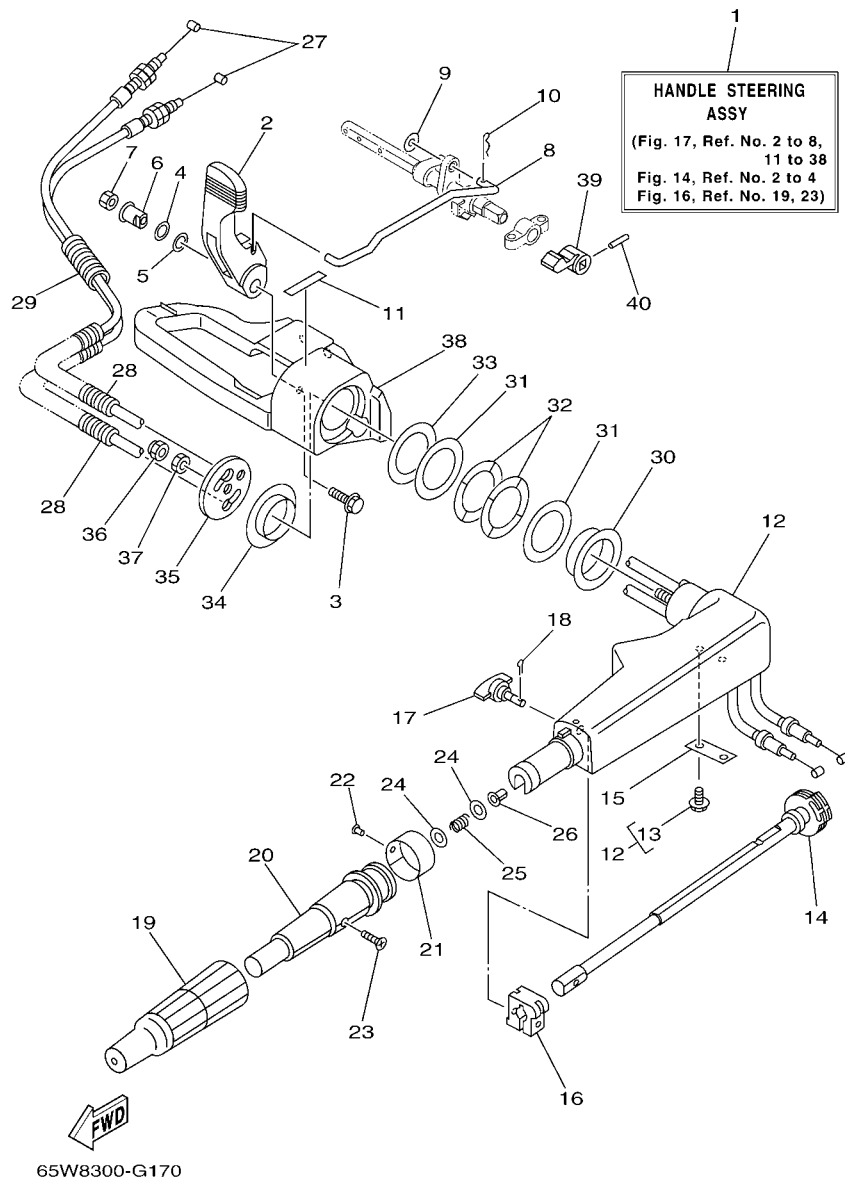
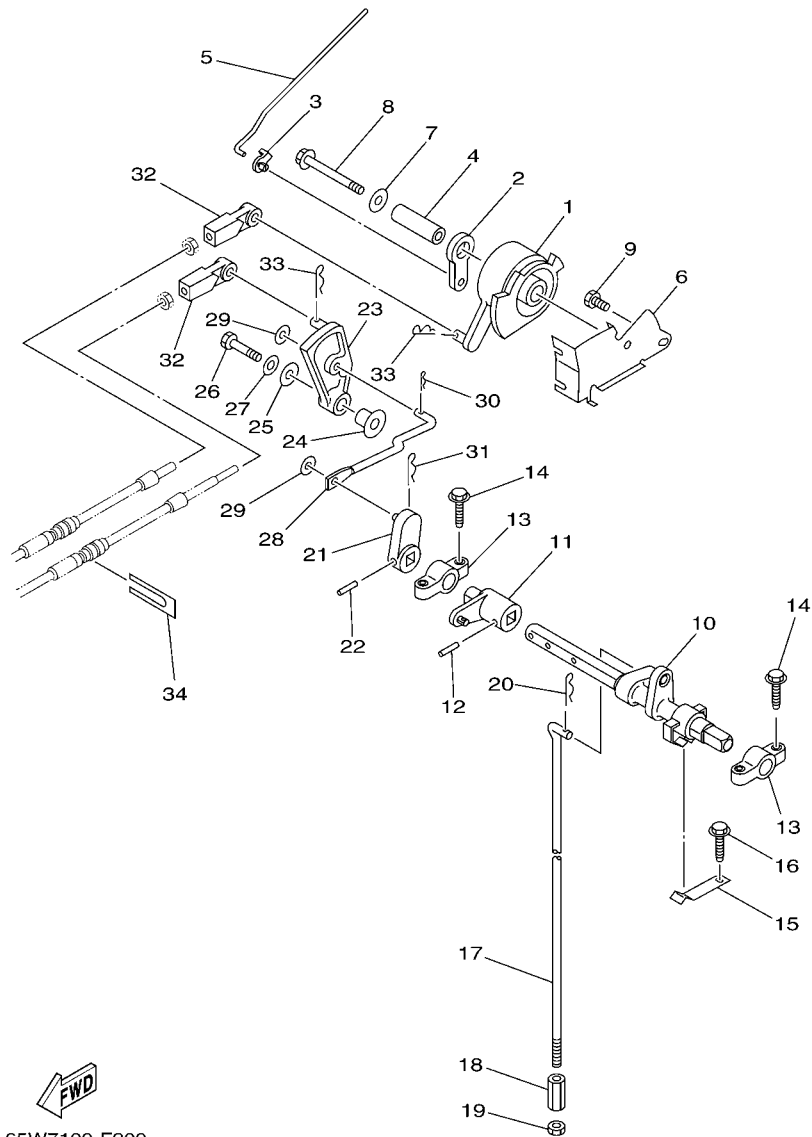

FIG. 17 STEERING

DIRECTION

REF. NO.	PART NO. N° PIECES	DESCRIPTION DESCRIPTION	MH	E	ET	REMARKS REMARQUES
28	90446-10M86	HOSE (L140) DURITE (L140)	2			
29	90446-14M88	HOSE DURITE	1			
30	90386-40MA0	BUSH DOUILLE	1			
31	90201-43M00	WASHER, PLATE RONDELLE, PLATE	2			
32	90206-43M22	WASHER, WAVE RONDELLE, ONDULEE	2			
33	90202-43M57	WASHER, PLATE RONDELLE, PLATE	1			
34	90386-40M99	BUSH DOUILLE	1			
35	65W-42131-01	COVER, HANDLE STEERING COUVERCLE	1			
36	95780-10300	NUT, FLANGE ECROU	1			
37	95380-10700	NUT ECROU	1			
38	65W-42121-01-4D	BRACKET SUPPORT	1			
39	65W-44173-01	LEVER, SHIFT CONTROL POIGNEE, INVERSION		1	1	
40	90254-03M05	PIN, SPRING RIVET, TETE TRONCONIQUE		1	1	



65W7100-F200

FIG. 18 CONTROL

COMMANDE

REF. NO.	PART NO. N° PIECES	DESCRIPTION DESCRIPTION	MH	E	ET	REMARKS REMARQUES
1	65W-41638-00	PULLEY POULIE	1	1	1	
2	65W-41283-00	LEVER, FREE ACCEL. LEVIER	1	1	1	
3	661-41262-02	JOINT, CHOKE LEVER RACCORD, LEVIER DE STARTER	1	1	1	
4	90387-06064	COLLAR COLLERETTE	1	1	1	
5	65W-41211-00	LINK, ACCEL. BIELLE, ACCELERATION	1	1	1	
6	65W-14497-01	STAY, THROTTLE WIRE SUPPORT DE BOISSEAU	1	1	1	
7	90201-06M31	WASHER, PLATE RONDELLE, PLATE	1	1	1	
8	97595-06555	BOLT, WITH WASHER VIS HEXAGONAL AVC RONDELLE	1	1	1	
9	97095-06010	BOLT BOULON	1	1	1	
10	65W-44121-00	LEVER, SHIFT ROD LEVIER, TIGE D'INVERSION	1	1	1	
11	65W-44122-00	BUSHING, SHIFT ROD LEVER DOUILLE, LEVIER D'EMBRAYAGE	1	1	1	
12	90254-03M05	PIN, SPRING RIVET, TETE TRONCONIQUE	1	1	1	
13	6F5-41662-00	BRACKET 2 SUPPORT 2	2	2	2	
14	90109-06M81	BOLT BOULON	4	4	4	
15	65W-44116-00	SPRING RESSORT	1	1	1	
16	90109-06M86	BOLT BOULON	1	1	1	
17	65W-44143-00	ROD, SHIFT TIGE D'EMBRAYAGE	1	1		S(16.6") S(16.6")
	65W-44143-10	ROD, SHIFT TIGE D'EMBRAYAGE	1	1	1	L(21.6") L(21.6")
18	90170-06015	NUT ECROU	1	1	1	
19	95380-06700	NUT ECROU	1	1	1	
20	90468-18008	CLIP JONC	1	1	1	
21	65W-44142-00	JOINT AXE		1	1	
22	90254-03M05	PIN, SPRING RIVET, TETE TRONCONIQUE		1	1	
23	65W-44125-00	LEVER, SHIFT ROD LEVIER, TIGE D'INVERSION		1	1	
24	90387-06M29	COLLAR COLLERETTE		1	1	
25	90201-06M31	WASHER, PLATE RONDELLE, PLATE		1	1	
26	97095-06025	BOLT BOULON		1	1	

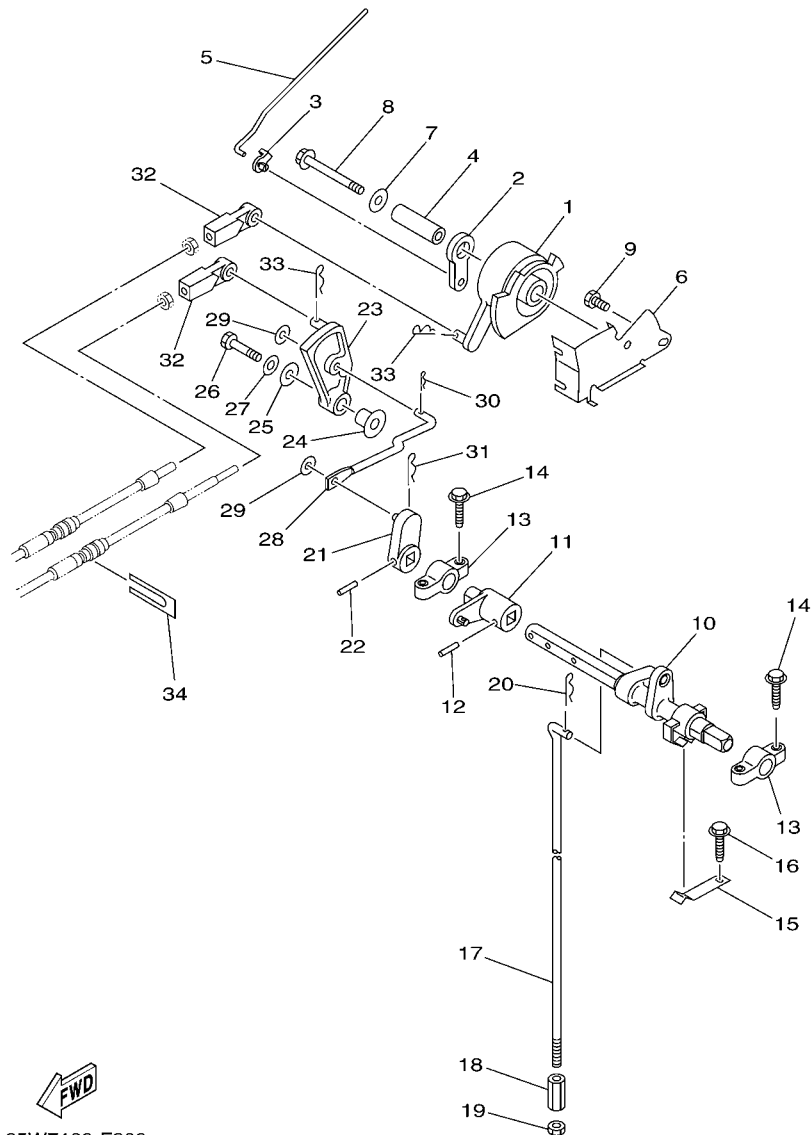

65W7100-F200

FIG. 18 CONTROL

COMMANDE

REF. NO.	PART NO. N° PIECES	DESCRIPTION DESCRIPTION	MH	E	ET	REMARKS REMARQUES
27	92995-06600	WASHER RONDELLE		1	1	
28	65W-44192-00	JOINT, ROD 1 RACCORD 1, BIELLETTE		1	1	
29	90201-05M06	WASHER, PLATE RONDELLE, PLATE		2	2	
30	90468-10005	CLIP JONC		1	1	
31	90468-18008	CLIP JONC		1	1	
32	663-48344-00	CABLE END, REMOTE CONTROL CHAPE CABLE		2	2	
33	90468-18008	CLIP JONC		2	2	
34	6H3-48538-00	CLAMP, CABLE 1 COLLIER		1	1	

FIG. 19 REMO CON ATTACHMENT

COMMANDE A DISTANCE

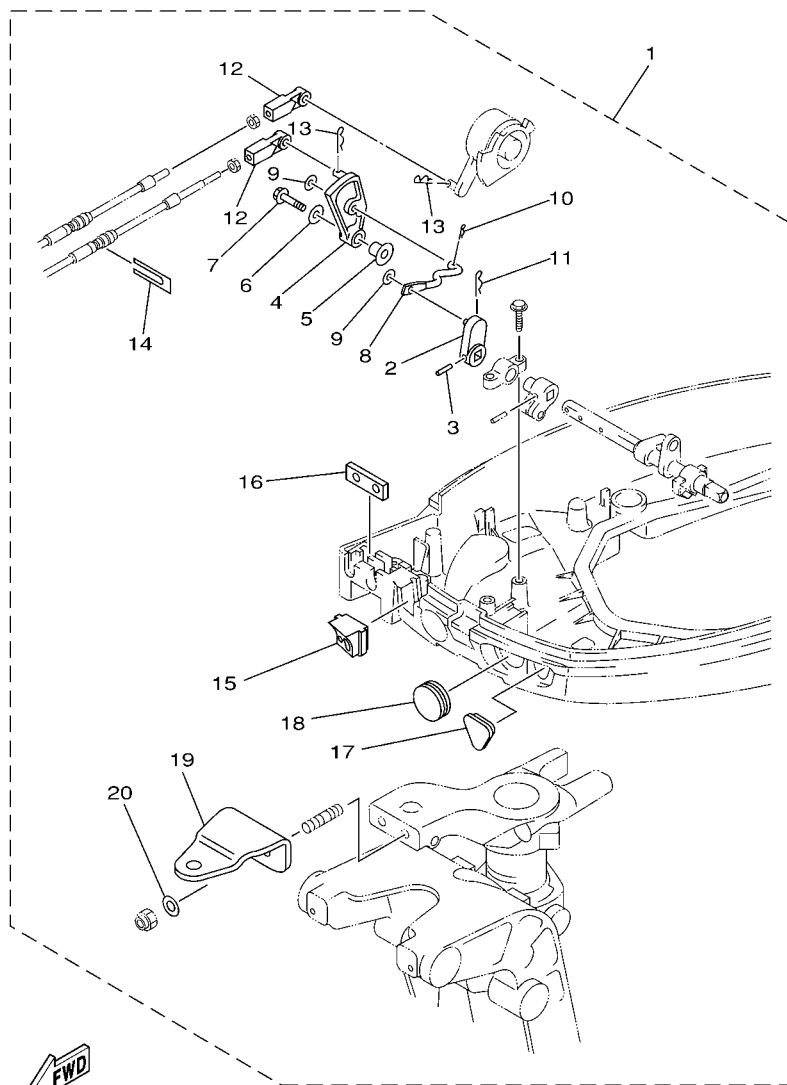

65W0010-9200

REF. NO.	PART NO. N° PIECES	DESCRIPTION DESCRIPTION	MH	E	ET	REMARKS REMARQUES
1	65W-48501-00	REMOTE CONT. ATTACHMENT ASSY. COMMANDE A DISTANCE (KIT)	1			AP AP
2	65W-44142-00	.JOINT .AXE	1			
3	90254-03M05	.PIN, SPRING .RIVET, TETE TRONCONIQUE	1			
4	65W-44125-00	.LEVER, SHIFT ROD .LEVIER, TIGE D'INVERSION	1			
5	90387-06M29	.COLLAR .COLLERETTE	1			
6	90201-06M31	.WASHER, PLATE .RONDELLE, PLATE	1			
7	97595-06525	.BOLT, WITH WASHER .VIS HEXAGONAL AVC RONDELLE	1			
8	65W-44192-00	.JOINT, ROD 1 .RACCORD 1, BIELLETTE	1			
9	90201-05M06	.WASHER, PLATE .RONDELLE, PLATE	2			
10	90468-10005	.CLIP .JONC	1			
11	90468-18008	.CLIP .JONC	1			
12	663-48344-00	.CABLE END, REMOTE CONTROL .CHAPE CABLE	2			
13	90468-18008	.CLIP .JONC	2			
14	6H3-48538-00	.CLAMP, CABLE 1 .COLLIER	1			
15	65W-42725-21	.GROMMET .PASSE-FIL	1			
16	62Y-42727-00	.GROMMET .PASSE-FIL	1			
17	65W-26326-10	.GROMMET .RONDELLE CAOUTCHOUC	1			
18	65W-42726-10	.GROMMET .PASSE-FIL	1			
19	65W-48511-00	.HOOK, STEERING .ATTACHE, DIRECTION	1			
20	90201-10120	.WASHER, PLATE .RONDELLE, PLATE	2			

FIG. 20 BRACKET 1

SUPPORT 1

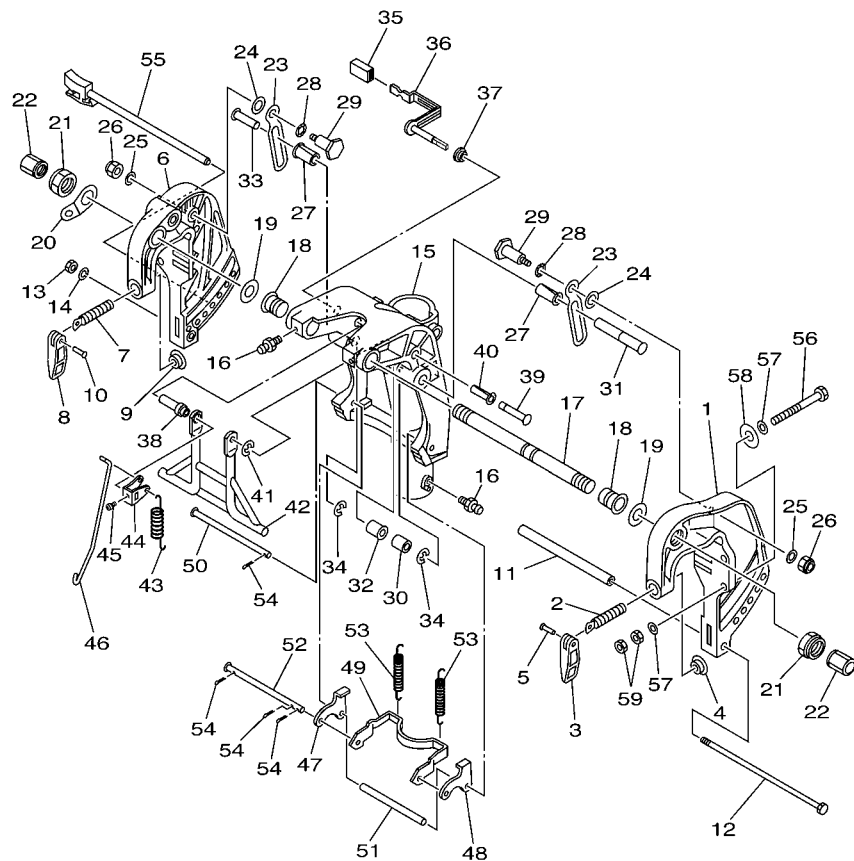

65W41 10-D220

REF. NO.	PART NO. N° PIECES	DESCRIPTION DESCRIPTION	MH	E	ET	REMARKS REMARQUES
1	66T-43111-01-4D	BRACKET, CLAMP 1 PRESSE 1	1	1		
2	90149-14M12	SCREW VIS	1	1		
3	663-43118-01-4D	HANDLE, TRANSOM CLAMP POIGNEE DE VIS DE PRESSE	1	1		
4	648-43114-01	PAD, TRANSOM CLAMP RONDELLE D'APPUI	1	1		
5	90243-04007	PIN GOUPILLE	1	1		
6	66T-43112-01-4D	BRACKET, CLAMP 2 PRESSE 2	1	1		
7	90149-14M12	SCREW VIS	1	1		
8	663-43118-01-4D	HANDLE, TRANSOM CLAMP POIGNEE DE VIS DE PRESSE	1	1		
9	648-43114-01	PAD, TRANSOM CLAMP RONDELLE D'APPUI	1	1		
10	90243-04007	PIN GOUPILLE	1	1		
11	90387-08M29	COLLAR COLLERETTE	1	1		
12	90101-08M76	BOLT BOULON	1	1		
13	95380-08600	NUT ECROU	1	1		
14	92990-08100	WASHER, SPRING RONDELLE, GROWER	1	1		
15	65W-43311-00-4D	BRACKET, SWIVEL 1 SUPPORT, PIVOT 1	1	1		S(16.6") S(16.6")
15	65W-43311-10-4D	BRACKET, SWIVEL 1 SUPPORT, PIVOT 1	1	1		L(21.6") L(21.6")
16	93700-06M03	NIPPLE, GREASE PION	3	3		
17	63D-43131-01	BOLT, CLAMP BRACKET BOULON, PRESSE	1	1		
18	90386-22M15	BUSH DOUILLE	2	2		
19	90201-22M03	WASHER, PLATE RONDELLE, PLATE	2	2		
20	6J8-43113-01	PLATE, CLAMP BRACKET PLAQUETTE, PRESSE	1	1		
21	90185-22M11	NUT, SELF-LOCKING ECROU,AUTO-BLOQUANT	2	2		
22	6G5-43145-01	CAP, CLAMP BRACKET CAPUCHON, PRESSE	2	2		
23	66T-43627-00	STOPPER PLAQUETTE	2	2		
24	90202-12031	WASHER, PLATE RONDELLE, PLATE	2	2		
25	90201-08M07	WASHER, PLATE RONDELLE, PLATE	2	2		
26	90185-08057	NUT, SELF-LOCKING ECROU,AUTO-BLOQUANT	2	2		

FIG. 20 BRACKET 1

SUPPORT 1

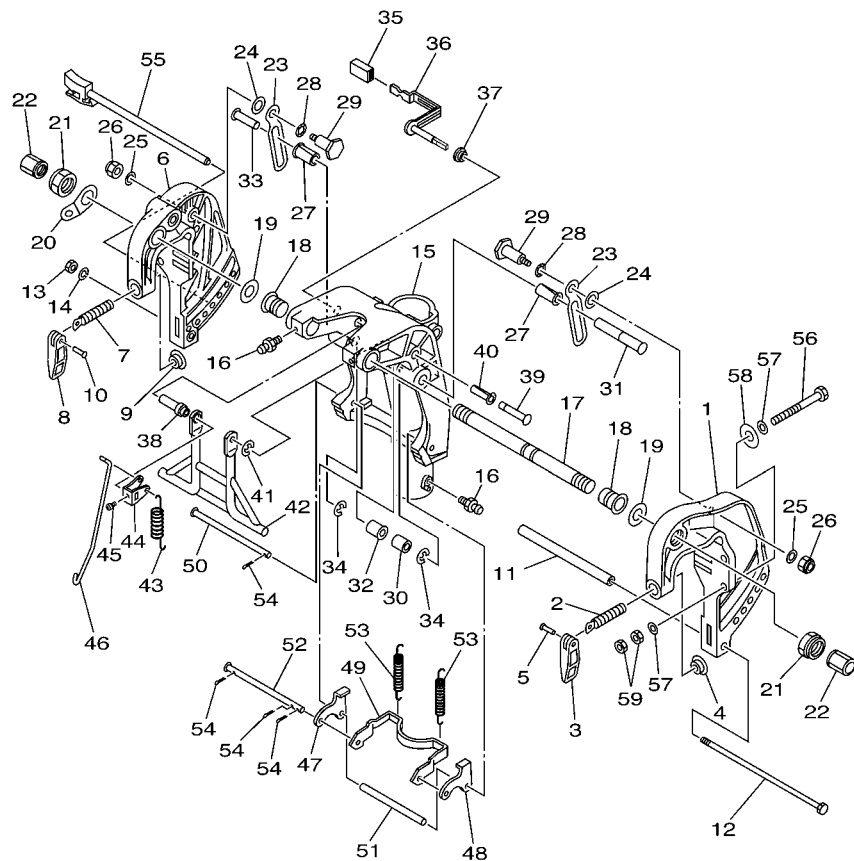

65W41 10-D220

REF. NO.	PART NO. N° PIECES	DESCRIPTION DESCRIPTION	MH	E	ET	REMARKS REMARQUES
27	90386-12M98	BUSH DOUILLE	2	2		
28	90206-12M00	WASHER, WAVE RONDELLE, ONDULEE	2	2		
29	90109-08M90	BOLT BOULON	2	2		
30	90387-12M04	COLLAR COLLERETTE	1	1		
31	90249-12M39	PIN GOUILLE	1	1		
32	90386-12MA0	BUSH DOUILLE	1	1		
33	90249-12M34	PIN GOUILLE	1	1		
34	93430-10M00	CIRCLIP CLIPS	2	2		
35	682-43318-01	COVER CAPUCHON	1	1		
36	65W-43630-11	TILT LEVER ASSY LEVIER D'INCLINAISON	1	1		
37	90386-07MA2	BUSH DOUILLE	1	1		
38	90387-07M05	COLLAR COLLERETTE	1	1		
39	90249-10M31	PIN GOUILLE	1	1		
40	90386-10M99	BUSH DOUILLE	1	1		
41	99080-08600	CIRCLIP CIRCLIP	1	1		
42	66T-43350-02	RECEIVER ASSY RECEIVER ASSY	1	1		
43	90506-20M37	SPRING, TENSION RESSORT, TENSION	1	1		
44	66T-43631-11	LEVER, TILT LEVIER, INCLINAISON	1	1		
45	90157-05014	SCREW, PAN HEAD VIS, TETE TRONCONIQUE	1	1		
46	65W-43616-00	ROD, TILT LOCK TIGE	1	1		
47	65W-43614-01	PLATE, TILT LOCK ETRIER, VERROUILLAGE MARCHE AR	1	1		
48	65W-43615-01	PLATE, TILT LOCK ETRIER, VERROUILLAGE MARCHE AR	1	1		
49	65W-43613-00	ARM, TILT LOCK GUIDE	1	1		
50	90249-07M32	PIN GOUILLE	1	1		
51	90387-07M29	COLLAR COLLERETTE	1	1		
52	90249-07M33	PIN GOUILLE	1	1		
53	90506-30M00	SPRING, TENSION RESSORT, TENSION	2	2		

FIG. 20 BRACKET 1

SUPPORT 1

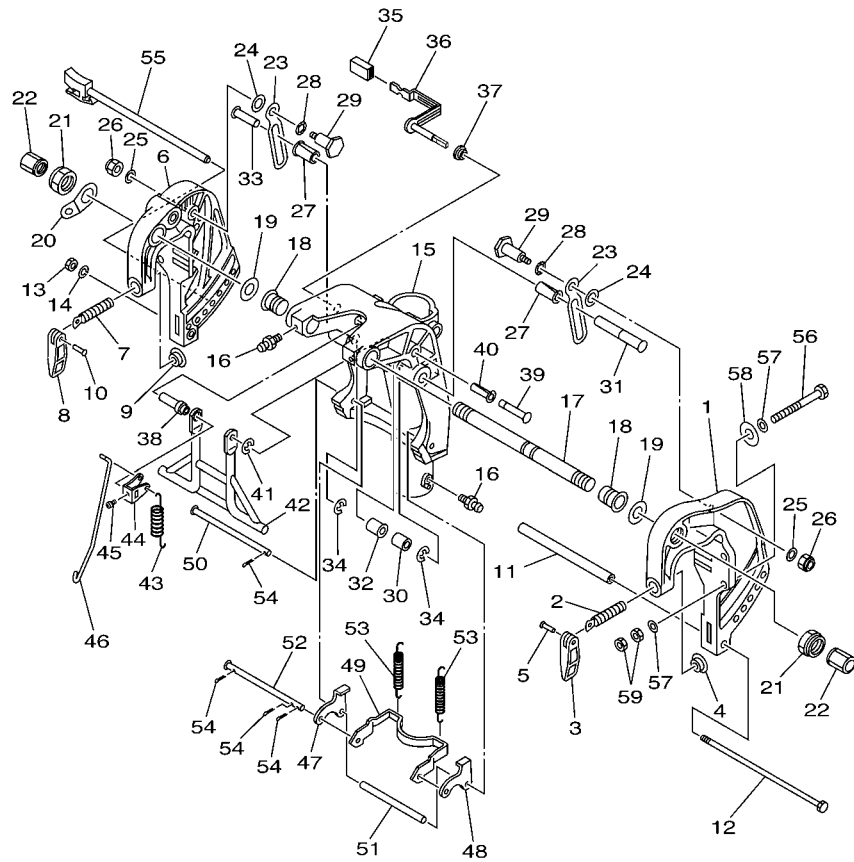

REF. NO.	PART NO. N° PIECES	DESCRIPTION DESCRIPTION	MH	E	ET	REMARKS REMARQUES
54	91490-20012	PIN, COTTER GOUILLE	4	4		
55	65W-43160-00	TILT ROD ASSY BROCHE D'INCLINAISON (ENS.)	1	1		
56	90101-10M58	BOLT BOULON		4		
57	92995-10600	WASHER RONDELLE		8		
58	90201-12426	WASHER, PLATE RONDELLE, PLATE		4		
59	95380-10600	NUT ECROU		8		
<hr/>						
<hr/>						
<hr/>						
<hr/>						
<hr/>						
<hr/>						
<hr/>						
<hr/>						
<hr/>						
<hr/>						

 65W4110-D220

FIG. 22 BRACKET 3

SUPPORT 3

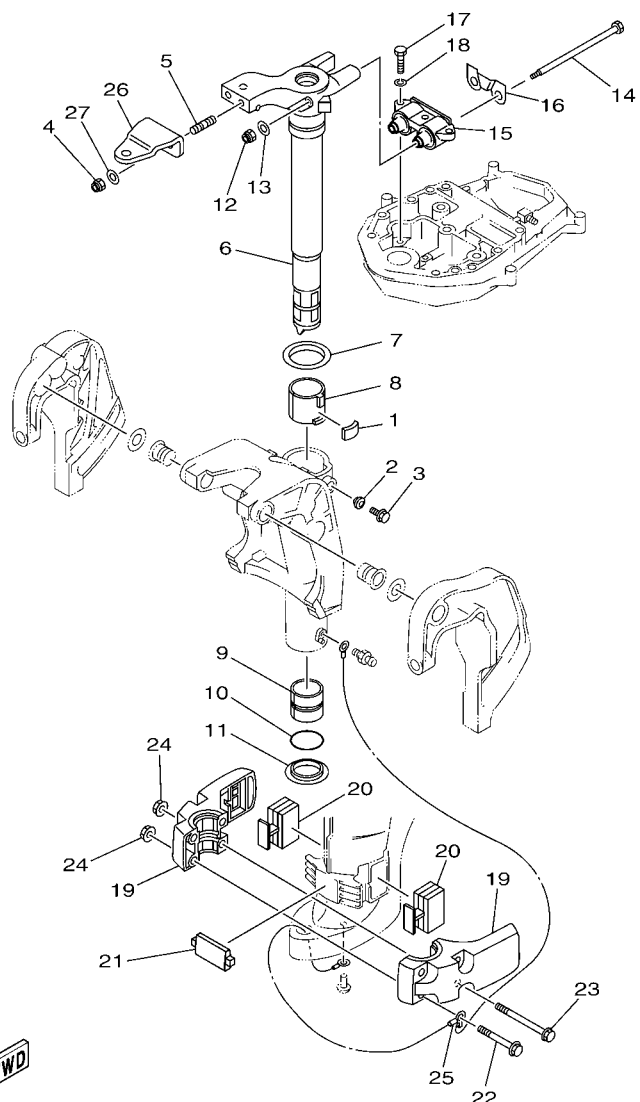

65W7100-F240

REF. NO.	PART NO. N° PIECES	DESCRIPTION DESCRIPTION	MH	E	ET	REMARKS REMARQUES
1	648-42528-00	PLATE, FRICTION PLAQUE, FRICTION	1	1	1	
2	65W-43373-00	SEAL, DAMPER JOINT	1	1	1	
3	90105-08M76	BOLT, FLANGE BOULON	1	1	1	
4	90185-10051	NUT, SELF-LOCKING ECROU,AUTO-BLOQUANT	2	2	2	
5	90116-10M28	BOLT, STUD GOUJON	2	2	2	
6	65W-42511-00-4D	BRACKET, STEERING CADRE, DIRECTION	1	1		S(16.6") S(16.6")
	65W-42511-10-4D	BRACKET, STEERING CADRE, DIRECTION	1	1	1	L(21.6") L(21.6")
7	90209-52M00	WASHER RONDELLE	1	1	1	
8	90386-52M02	BUSH DOUILLE	1	1	1	
9	90386-44M03	BUSH DOUILLE	1	1	1	
10	93210-43MJ0	O-RING JOINT TORIQUE	1	1	1	
11	90386-44M99	BUSH DOUILLE	1	1	1	
12	90185-08045	NUT, SELF-LOCKING ECROU,AUTO-BLOQUANT	2	2	2	
13	92995-08200	WASHER RONDELLE	2	2	2	
14	90101-08M86	BOLT BOULON	2	2	2	
15	67C-44514-20-4D	MOUNT DAMPER, UPPER SIDE SILENT-BLOC, SUPERIEUR LATERAL	1	1	1	
16	66T-44526-30	PLATE PLAQUE	1	1	1	
17	97075-08030	BOLT BOULON	3	3	3	
18	92995-08100	WASHER RONDELLE	3	3	3	
19	65W-44551-11-4D	HOUSING, LOWER MOUNT RUBBER BOITIER, SILENT-BLOC INFERIEUR	2	2	2	
20	65W-44555-00	MOUNT DAMPER, LOWER SIDE SILENT-BLOC, INFERIEUR LATERAL	2	2	2	
21	65W-44575-01	DAMPER, LOWER MOUNT RUBBER SILENT-BLOC, INFERIEUR	1	1	1	
22	97575-10580	BOLT, WITH WASHER VIS HEXAGONAL AVEC RONDELLE	2	2	2	
23	90119-10M14	BOLT, WITH WASHER BOULON, AVEC RONDELLE	2	2	2	
24	90179-10M33	NUT ECROU	4	4	4	
25	65W-82127-10	WIRE, LEAD 2 FIL 2	1	1	1	
26	65W-48511-00	HOOK, STEERING ATTACHE, DIRECTION		1	1	

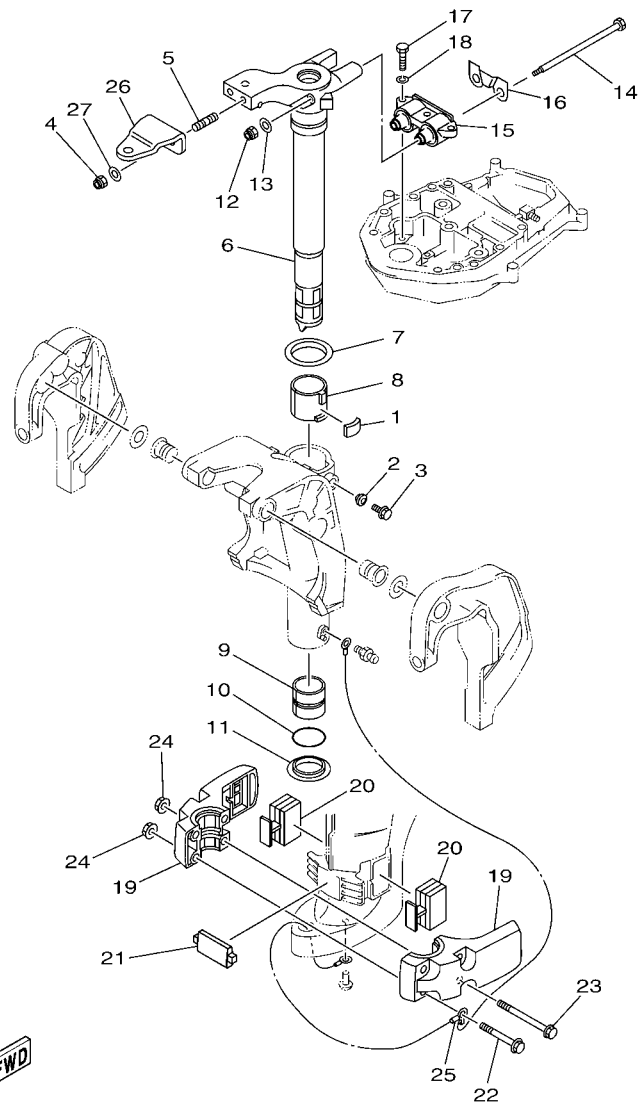

65W7100-F240

FIG. 22 BRACKET 3

SUPPORT 3

REF. NO.	PART NO. N° PIECES	DESCRIPTION DESCRIPTION	MH	E	ET	REMARKS REMARQUES
27	90201-10120	WASHER, PLATE RONDELLE, PLATE		2	2	

FIG. 24 UPPER CASING

FOURREAU

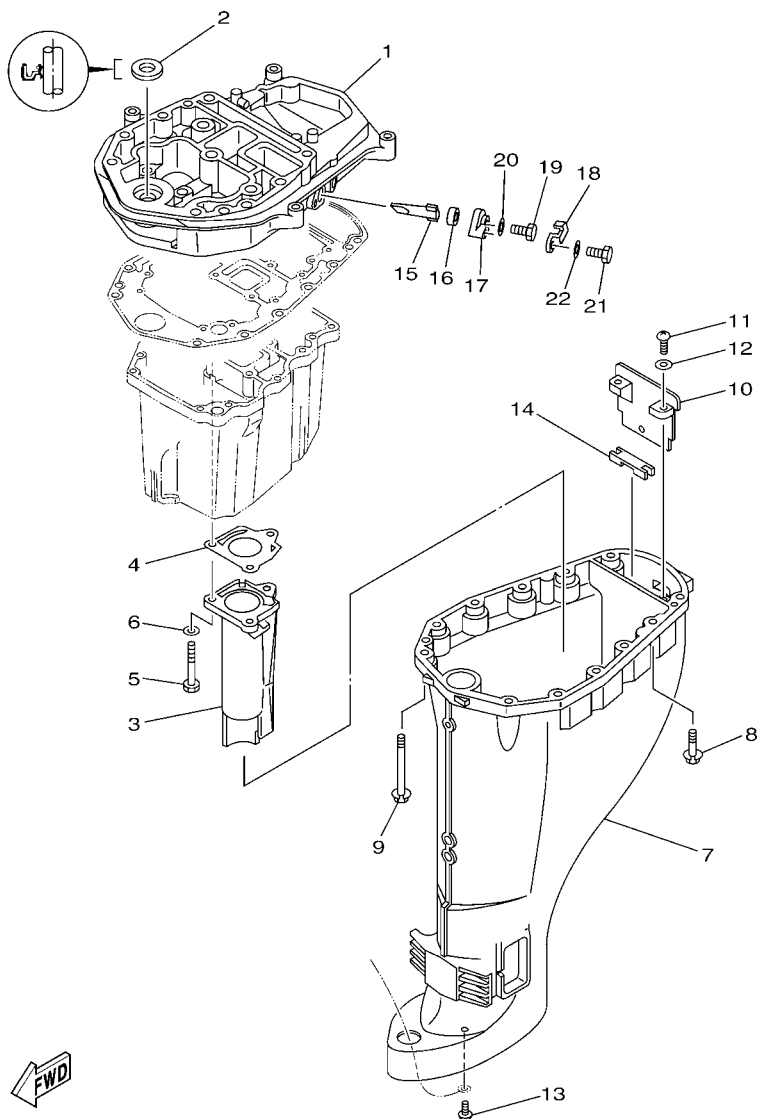

65W5100-E260

REF. NO.	PART NO. N° PIECES	DESCRIPTION DESCRIPTION	MH	E	ET	REMARKS REMARQUES
1	65W-41137-11-94	GUIDE, EXHAUST COLLECTEUR D'ECHAPPEMENT	1	1	1	
2	93110-16004	OIL SEAL JOINT SPY	1	1	1	
3	68U-41131-00-5B	MANIFOLD, EXT. 1 PIPE D'ECHAPPEMENT	1	1	1	
4	67C-41133-00	GASKET, EXHAUST MANIFOLD 1 JOINT, PIPE D'ECHAPPEMENT	1	1	1	
5	97075-06050	BOLT BOULON	3	3	3	
6	92995-06600	WASHER RONDELLE	3	3	3	
7	6D5-45111-A0-4D	CASING, UPPER FOURREAU	1	1		S(16.6") S(16.6")
	6D5-45111-10-4D	CASING, UPPER FOURREAU	1	1	1	L(21.6") L(21.6")
8	90119-08M79	BOLT, WITH WASHER BOULON, AVEC RONDELLE	4	4	4	
9	90119-08M82	BOLT, WITH WASHER BOULON, AVEC RONDELLE	8	8	8	
10	65W-45151-00	COVER, UPPER CASING CAPUCHON, FOURREAU	1	1	1	
11	97880-05016	SCREW, PAN HEAD VIS, TETE TRONCONIQUE	2	2	2	
12	92990-05600	WASHER, PLATE RONDELLE, PLATE	2	2	2	
13	90157-06M06	SCREW, PAN HEAD VIS, TETE TRONCONIQUE	1	1	1	
14	65W-45128-00	SEAL 2 JOINT 2	1	1	1	
15	62Y-11325-00	ANODE ANODE	1	1	1	
16	66M-11328-00	GROMMET, ANODE PASSE-FIL	1	1	1	
17	66M-11327-00-94	COVER, ANODE COUVERCLE ANODE	1	1	1	
18	66M-12535-00	PLATE PLAQUE	1	1	1	
19	97095-05012	BOLT BOULON	1	1	1	
20	92995-05600	WASHER RONDELLE	1	1	1	
21	97013-06020	BOLT BOULON	1	1	1	
22	92903-06600	WASHER, PLATE RONDELLE, PLATE	1	1	1	

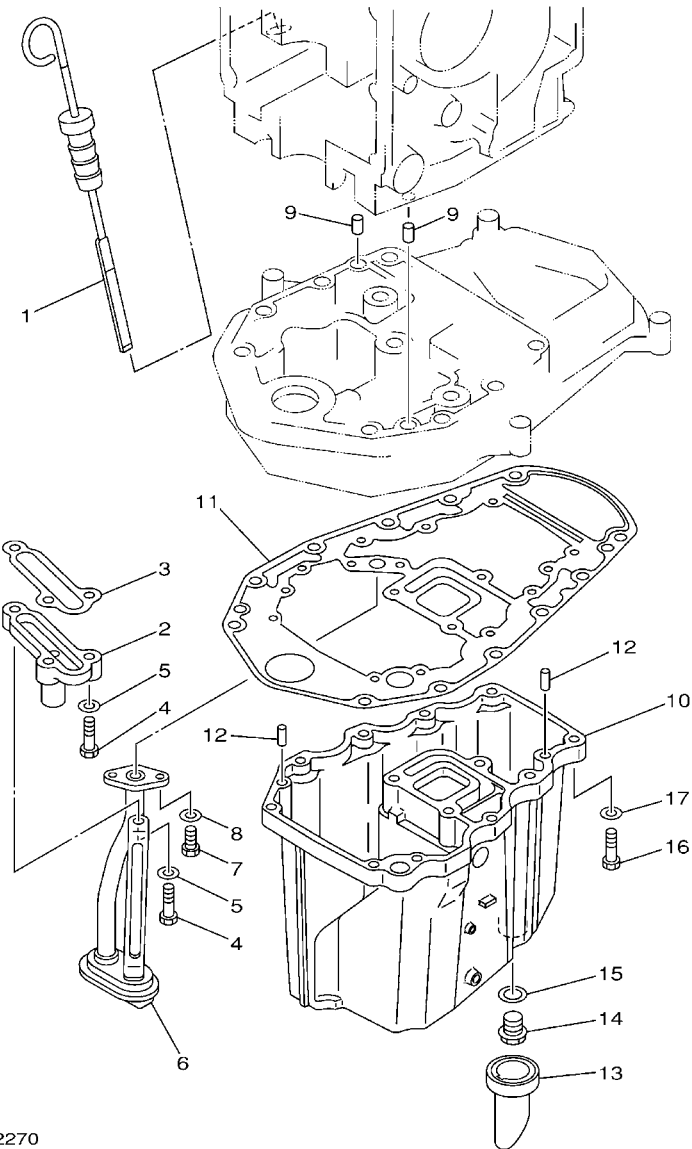

65W1010-2270

FIG. 25 OIL PAN

VENTILATEUR D'HUILE

REF. NO.	PART NO. N° PIECES	DESCRIPTION DESCRIPTION	MH	E	ET	REMARKS REMARQUES
1	65W-15362-01	PLUG, OIL LEVEL PLOT, NIVEAU D'HUILE	1	1	1	
2	62Y-11575-00	RELIEF VALVE ASSY SOUPAPE DE RENTREE D'AIR	1	1	1	
3	62Y-13475-00	GASKET JOINT	1	1	1	
4	97013-06025	BOLT BOULON	3	3	3	
5	92903-06600	WASHER, PLATE RONDELLE, PLATE	3	3	3	
6	65W-13411-00	STRAINER, OIL FILTRE, HUILE	1	1	1	
7	97013-06016	BOLT BOULON	2	2	2	
8	92903-06600	WASHER, PLATE RONDELLE, PLATE	2	2	2	
9	93608-12M05	PIN, DOWEL AXE	2	2	2	
10	65W-15311-02-5B	OIL PAN VENTILATEUR D'HUILE	1	1	1	
11	69W-15312-00	GASKET, OIL PAN JOINT DE VENTILATEUR D'HUILE	1	1	1	
12	93606-12019	PIN, DOWEL GÓUPILLE	4	4	4	
13	65W-15316-00	DAMPER, ENGINE MOUNT 1 AMORTISSEUR DE SUPPORT	1	1	1	
14	90340-14M06	PLUG, STRAIGHT SCREW PLOT, FILETE DROIT	1	1	1	
15	90430-14M09	GASKET JOINT	1	1	1	
16	97075-06025	BOLT BOULON	10	10	10	
17	92995-06600	WASHER RONDELLE	10	10	10	

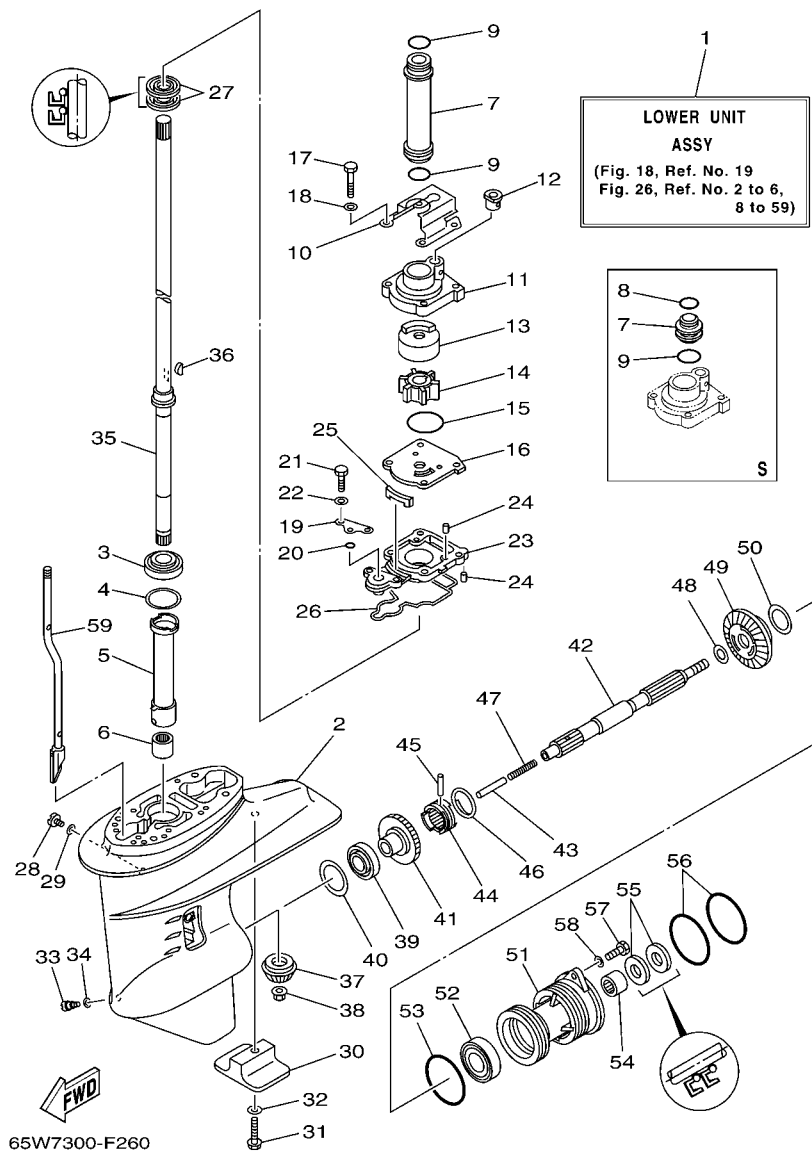

FIG. 26 LOWER CASING & DRIVE 1

BOITIER D'HELICE TRANSMISSION1

REF. NO.	PART NO. N° PIECES	DESCRIPTION DESCRIPTION	MH	E	Et	REMARKS REMARQUES
1	65W-45300-01-4D	LOWER UNIT ASSY UNITE INFERIEURE (ENS.)	1	1		S(16.6") S(16.6")
	65W-45300-11-4D	LOWER UNIT ASSY UNITE INFERIEURE (ENS.)	1	1	1	L(21.6") L(21.6")
2	61N-45311-02-4D	CASING, LOWER BOITIER D'HELICE	1	1	1	
3	93332-000W5	BEARING ROULEMENT	1	1	1	
4	61N-45587-00	SHIM (T:0.7MM) CALE (T:0.7MM)	1	1	1	UR UR
	61N-45587-10	SHIM (T:1.0MM) CALE (T:1.0MM)	1	1	1	UR UR
	61N-45587-20	SHIM (T:1.1MM) CALE (T:1.1MM)	1	1	1	UR UR
	61N-45587-30	SHIM (T:1.2MM) CALE (T:1.2MM)	1	1	1	UR UR
	61N-45587-40	SHIM (T:1.3MM) CALE (T:1.3MM)	1	1	1	UR UR
	61N-45587-50	SHIM (T:1.4MM) CALE (T:1.4MM)	1	1	1	UR UR
	61N-45587-60	SHIM (T:1.5MM) CALE (T:1.5MM)	1	1	1	UR UR
	61N-45587-70	SHIM (T:1.6MM) CALE (T:1.6MM)	1	1	1	UR UR
5	61N-45536-00	SLEEVE, DRIVE SHAFT MANCHON, ARBRE MOTEUR	1	1	1	
6	93315-220V7	BEARING ROULEMENT	1	1	1	
7	61N-44362-00	TUBE, WATER TUBE D'EAU	1	1		S(16.6") S(16.6")
	61N-44362-10	TUBE, WATER TUBE D'EAU	1	1	1	L(21.6") L(21.6")
8	93210-22164	O-RING JOINT TORIQUE	1	1		S(16.6") S(16.6")
9	93210-26130	O-RING JOINT TORIQUE	1	1		S(16.6") S(16.6")
	93210-26130	O-RING JOINT TORIQUE	2	2	2	L(21.6") L(21.6")
10	65W-44328-11	PLATE PLAQUETTE	1	1	1	L(21.6") L(21.6")
11	61N-44311-01	HOUSING, WATER PUMP CORPS, POMPE A EAU	1	1	1	
12	6L2-44367-00	DAMPER, WATER SEAL JOINT TUBE D'EAU	1	1	1	
13	61N-44322-01	INSERT, CARTRIDGE CUVETTE	1	1	1	
14	6H4-44352-02	IMPELLER TURBINE	1	1	1	
15	93210-45161	O-RING JOINT TORIQUE	1	1	1	
16	61N-44323-00	OUTER PLATE, CARTRIDGE PLAQUE EXTERIEURE	1	1	1	
17	97095-06040	BOLT BOULON	4	4	4	

FIG. 26 LOWER CASING & DRIVE 1

BOITIER D'HELICE TRANSMISSION1

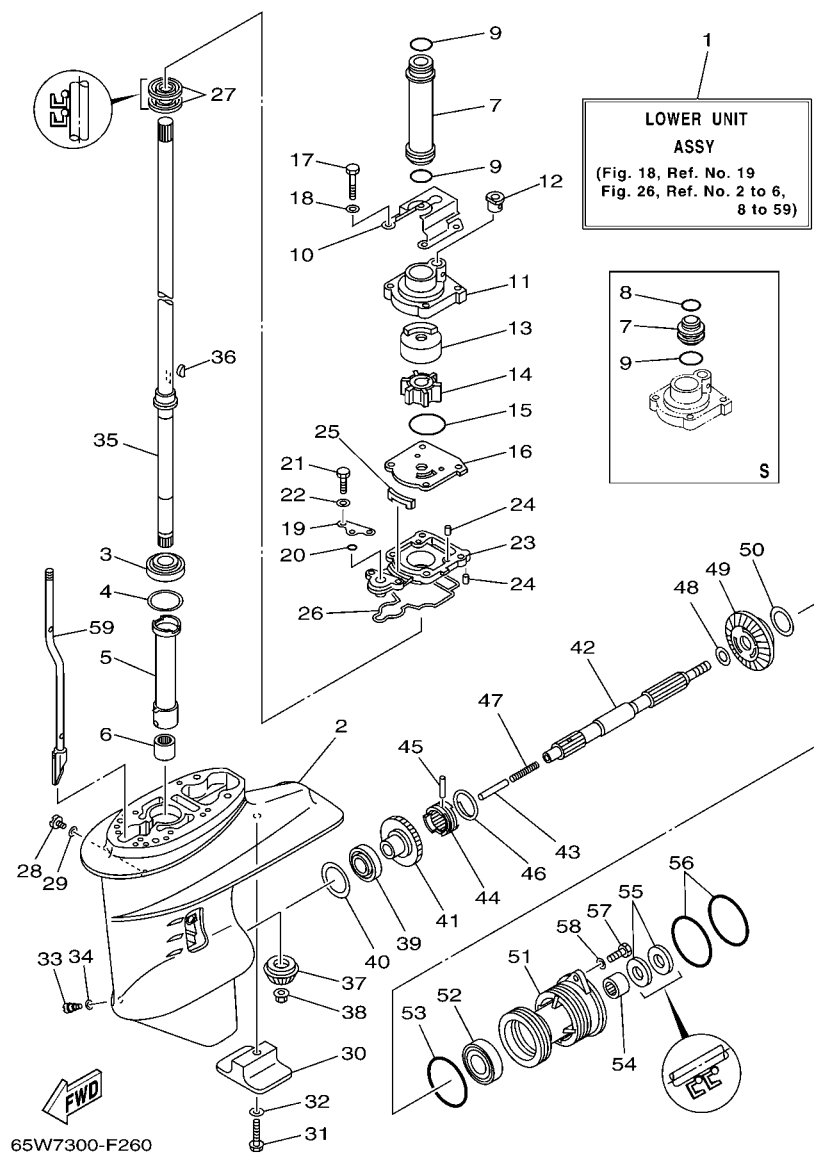

REF. NO.	PART NO. N° PIECES	DESCRIPTION DESCRIPTION	MH	E	ET	REMARKS REMARQUES
18	92995-06600	WASHER RONDELLE	4	4	4	
19	65W-44176-00	BRACKET SUPPORT	1	1	1	
20	93210-06ME6	O-RING JOINT TORIQUE	1	1	1	
21	97095-06025	BOLT BOULON	2	2	2	
22	92995-06600	WASHER RONDELLE	2	2	2	
23	65W-45331-00-5B	HOUSING, BEARING FLASQUE, ROULEMENT	1	1	1	
24	93604-10M03	PIN, DOWEL CLAVETTE	3	3	3	
25	61N-45127-00	SEAL JOINT	1	1	1	
26	61N-45315-00	PACKING, LOWER CASING JOINT, BOITIER D'HELICE	1	1	1	
27	93101-22067	OIL SEAL JOINT SPY	2	2	2	
28	90340-08002	PLUG, STRAIGHT SCREW PLOT, FILETE DROIT	1	1	1	
29	90430-08020	GASKET JOINT	1	1	1	
30	61N-45251-01	ANODE ANODE	1	1	1	
31	95895-06035	BOLT, FLANGE BOULON	1	1	1	
32	92990-06300	WASHER, INTERNAL TOOTH RONDELLE, DENTURE INTERNE	1	1	1	
33	688-45341-10	PLUG, DRAIN BOUCHON DE VIDANGE	1	1	1	
34	90430-08020	GASKET JOINT	1	1	1	
35	61N-45510-00	DRIVE SHAFT ASSY ARBRE MOTEUR (ENS.)	1	1		S(16.6") S(16.6")
	61N-45510-10	DRIVE SHAFT ASSY ARBRE MOTEUR (ENS.)	1	1	1	L(21.6") L(21.6")
36	90280-03024	KEY, WOODRUFF CLAVETTE, DEMI-LUNE	1	1	1	
37	61N-45551-00	PINION (13T) PIGNON D'ATTAQUE (13D)	1	1	1	
38	90179-10M14	NUT ECROU	1	1	1	
39	93332-00005	BEARING ROULEMENT	1	1	1	
40	6L2-45567-00	SHIM (T:1.0MM) CALE (T:1.0MM)	1	1	1	UR UR
	6L2-45567-10	SHIM (T:1.1MM) CALE (T:1.1MM)	1	1	1	UR UR
	6L2-45567-20	SHIM (T:1.2MM) CALE (T:1.2MM)	1	1	1	UR UR
	6L2-45567-30	SHIM (T:1.3MM) CALE (T:1.3MM)	1	1	1	UR UR

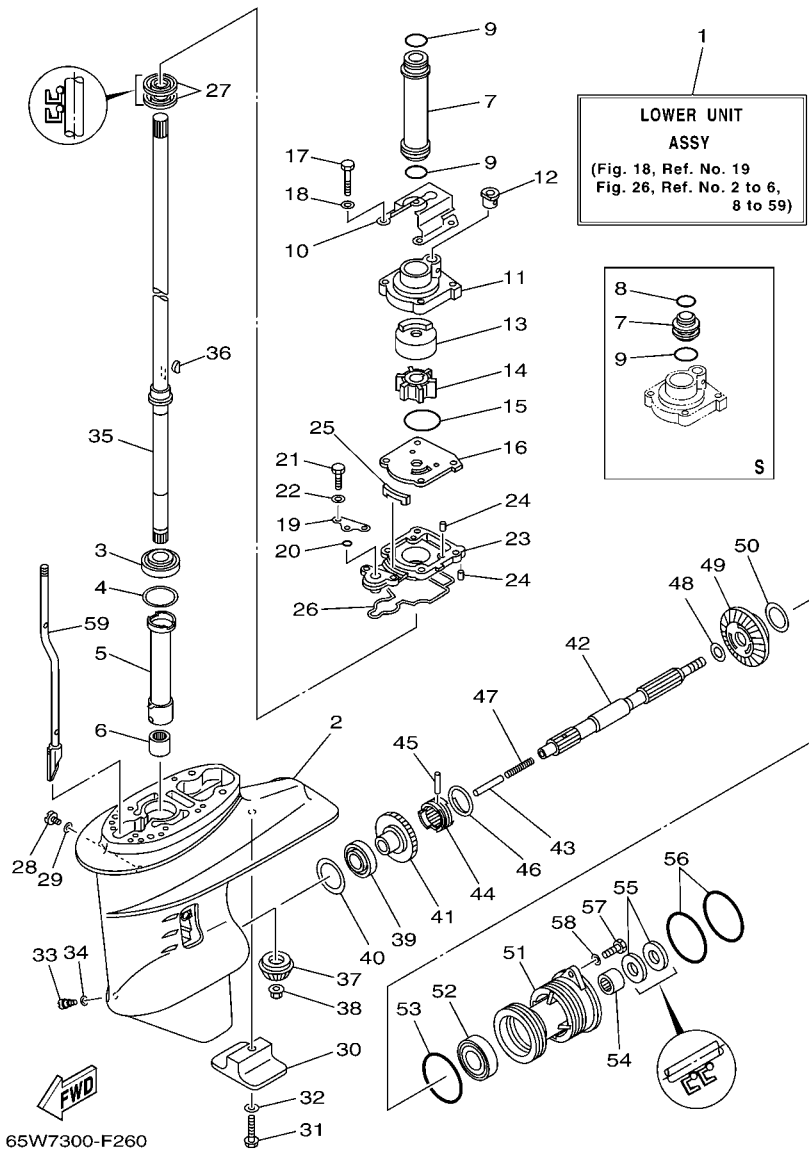

FIG. 26 LOWER CASING & DRIVE 1

BOITIER D'HELICE TRANSMISSION1

REF. NO.	PART NO. N° PIECES	DESCRIPTION DESCRIPTION	MH	E	ET	REMARKS REMARQUES
40	6L2-45567-40	SHIM (T:1.4MM) CALE (T:1.4MM)	1	1	1	UR UR
41	61N-45560-10	GEAR 1 (27T) PIGNON 1 (27T)	1	1	1	
42	65W-45611-00	SHAFT, PROPELLER ARBRE, HELICE	1	1	1	
43	648-45635-00	PLUNGER, SHIFT POUSSOIR D'EMBRAYAGE	1	1	1	
44	664-45631-02	CLUTCH, DOG CRABOT	1	1	1	
45	90250-05010	PIN, STRAIGHT GOUPILLE, DROITE	1	1	1	
46	648-45633-00	RING, CROSS PIN JONC, GOUPILLE CRABOT	1	1	1	
47	90501-10065	SPRING, COMPRESSION RESSORT, COMPRESSION	1	1	1	
48	90201-20417	WASHER, PLATE RONDELLE, PLATE	1	1	1	
49	61N-45571-00	GEAR 2 (27T) PIGNON 2 (27T)	1	1	1	
50	6L2-45577-00	SHIM (T:1.0MM) CALE (T:1.0MM)	1	1	1	UR UR
	6L2-45577-10	SHIM (T:1.1MM) CALE (T:1.1MM)	1	1	1	UR UR
	6L2-45577-20	SHIM (T:1.2MM) CALE (T:1.2MM)	1	1	1	UR UR
	6L2-45577-30	SHIM (T:1.3MM) CALE (T:1.3MM)	1	1	1	UR UR
51	61N-45361-01-4D	CAP, LOWER CASING COUVERCLE, BOITIER D'HELICE	1	1	1	
52	93306-00612	BEARING ROULEMENT	1	1	1	
53	93210-64ME7	O-RING JOINT TORIQUE	1	1	1	
54	93315-22004	BEARING ROULEMENT	1	1	1	
55	93101-20M07	OIL SEAL JOINT SPY	2	2	2	
56	93210-65M50	O-RING JOINT TORIQUE	2	2	2	
57	97075-06020	BOLT BOULON	2	2	2	
58	92995-06600	WASHER RONDELLE	2	2	2	
59	65W-44150-01	SHIFT CAM ASSY CAME D'INVERSION	1	1		S(16.6") S(16.6")
	65W-44150-11	SHIFT CAM ASSY CAME D'INVERSION	1	1	1	L(21.6") L(21.6")

FIG. 27 LOWER CASING & DRIVE 2

BOITIER D'HELICE TRANSMISSION2

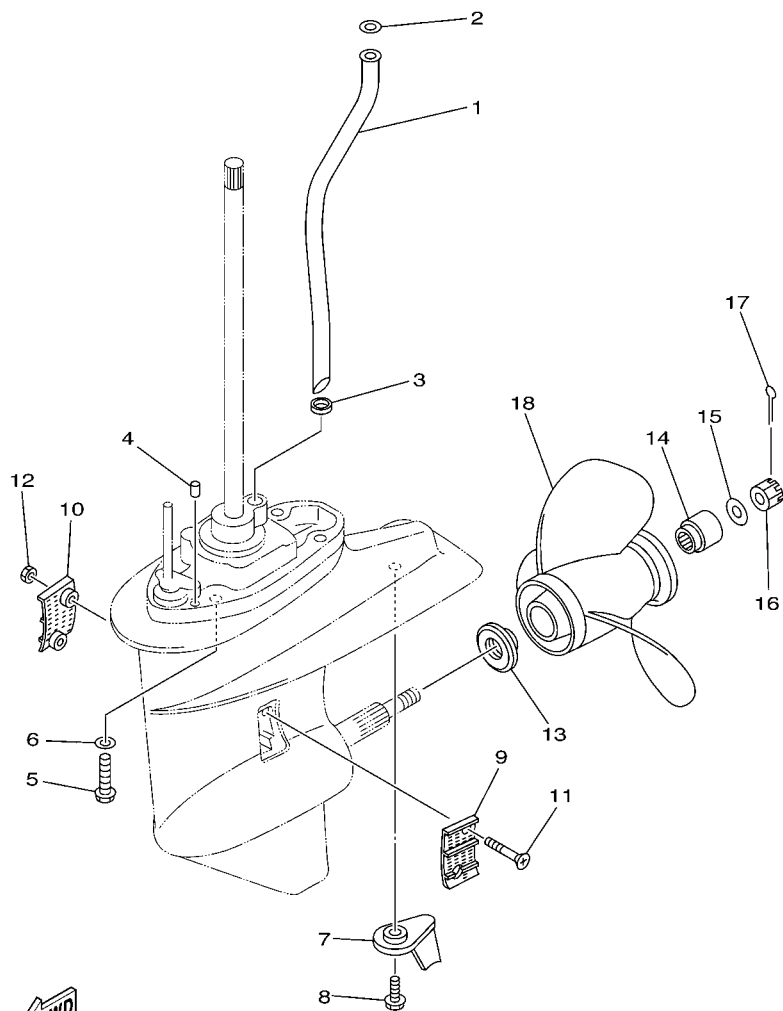

65W1100-2290

REF. NO.	PART NO. N° PIECES	DESCRIPTION DESCRIPTION	MH	E	ET	REMARKS REMARQUES
1	65W-44361-01	TUBE, WATER TUBE D'EAU	1	1		S(16.6") S(16.6")
	65W-44361-11	TUBE, WATER TUBE D'EAU	1	1	1	L(21.6") L(21.6")
2	90202-12060	WASHER, PLATE RONDELLE, PLATE	1	1	1	
3	90430-10002	GASKET JOINT	1	1	1	
4	93606-11M24	PIN, DOWEL GOUPILLE	2	2	2	
5	90105-10M12	BOLT, FLANGE BOULON	4	4	4	
6	92995-10600	WASHER RONDELLE	4	4	4	
7	61N-45371-00	TAB-TRIM ANODE DERIVE	1	1	1	
8	90119-06M48	BOLT, WITH WASHER BOULON, AVEC RONDELLE	1	1	1	
9	6L2-45214-00	COVER, WATER INLET 1 GRILLE, ENTREE D'EAU 1	1	1	1	
10	6L2-45215-00	COVER, WATER INLET 2 GRILLE, ENTREE D'EAU 2	1	1	1	
11	90151-05M05	SCREW, COUNTERSUNK VIS, TETE NOYEE	2	2	2	
12	90185-05002	NUT, SELF-LOCKING ECROU, AUTO-BLOQUANT	2	2	2	
13	6L2-45987-01	SPACER ENTRETOISE	1	1	1	
14	689-45997-00	SPACER ENTRETOISE	1	1	1	
15	92990-14200	WASHER, PLAIN RONDELLE, PLATE	1	1	1	
16	90171-14013	NUT, CASTLE ECROU, CRENELE	1	1	1	
17	91490-30022	PIN, COTTER GOUPILLE	1	1	1	
18	2506170	PROPELLER SOLAS (YB-3X9,90"X9") HELICE SOLAS (YB-3X9,90"X9")	1	1	1	UR UR
	2506180	PROPELLER SOLAS (YB-3X9,90"X10") HELICE SOLAS (YB-3X9,90"X10")	1	1	1	UR UR
	2506190	PROPELLER SOLAS (YB-3X9,90"X11") HELICE SOLAS (YB-3X9,90"X11")	1	1	1	UR UR
	2506200	PROPELLER SOLAS (YB-3X9,90"X12") HELICESOLAS (YB-3X9,90"X12")	1	1	1	UR UR
	2506210	PROPELLER SOLAS (YB-3X9,90"X13") HELICE SOLAS (YB-3X9,90"X13")	1	1	1	UR UR

FIG. 26 FUEL TANK 23 L

RESEVOIR A ESSENCE 23 L

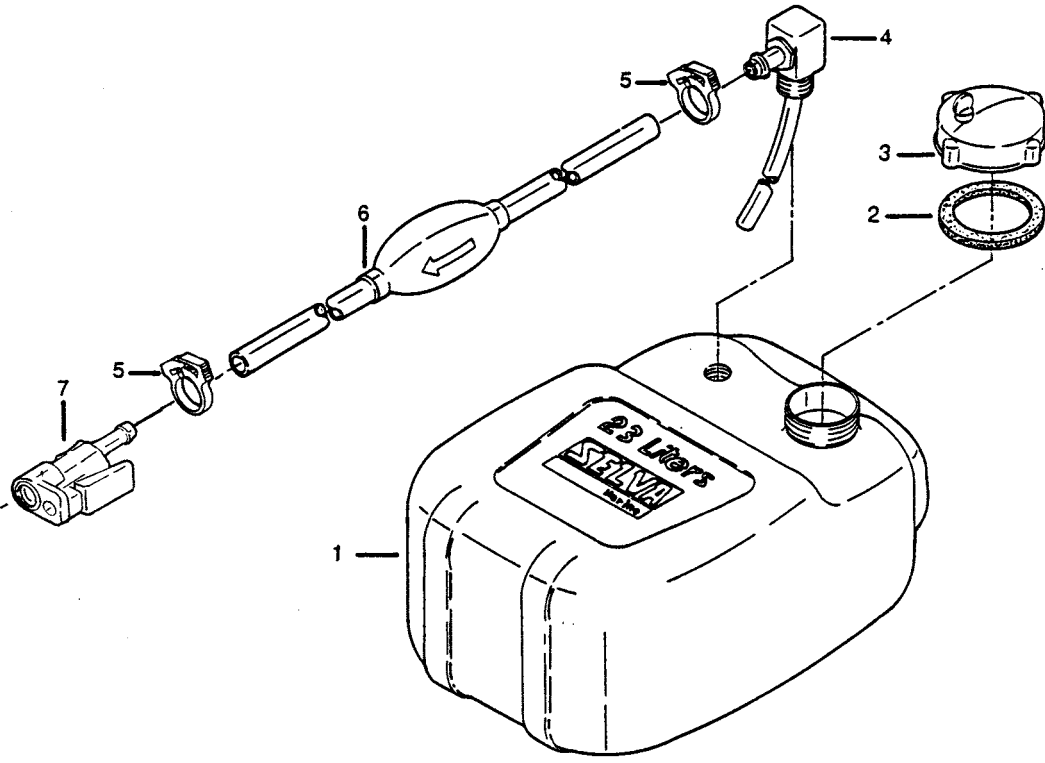

REF. NO.	PART NO. NO. PIECES	DESCRIPTION DESCRIPTION	M	W	REMARKS REMARQUES
1	8085080	COMPLETE FUEL TANK 23 L RESEVOIR A ESSENCE (ENS.) 23 L	1	1	
2	3540275	GASKET JOINT	1	1	
3	1598845	FUEL TANK PLUG (POS. NO 2+3) BOUCHON (ENS.) (POS. 2+3)	1	1	
4	8055085	COMPLETE FUEL SUCTION DURITE DE SUCCION	1	1	
5	8055101	CLAMP COLLIER	2	2	
6	8050270	FUEL HOSE DURITE A ESSENCE	1	1	
7	6G1-24305-01	FUEL CONNECTOR - FEMALE DURITE RACCORDEMENT A ESSENCE	1	1	
	1575270	FUEL TANK WITH PIPE RESEVOIR A ESSENCE + DURITE	1	1	
	1581280	COMPLETE PIPE (POS.NO. 5+6+7) DURITE A ESSENCE (ENS) (POS. 5+6+7)	1	1	

FIG. 29 STEERING GUIDE

FIXATION DE DIRECTION

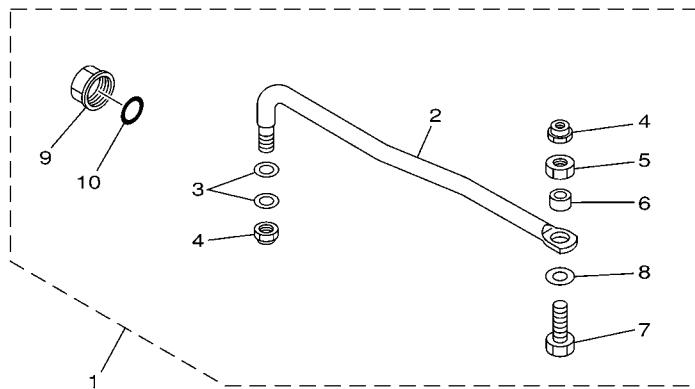

65W0010-8210

REF. NO.	PART NO. N° PIECES	DESCRIPTION DESCRIPTION	MH	E	ET	REMARKS REMARQUES
1	65W-61350-00	STEERING GUIDE ATTACHMENT KIT FIXATIONS DE DIRECTION		1	1	AP AP
2	65W-61351-00	.ROD, STEERING LINK .RENOI DE DIRECTION		1	1	
3	90201-10M20	.WASHER, PLATE .RONDELLE, PLATE		2	2	
4	90185-09M01	.NUT, SELF-LOCKING .ECROU,AUTO-BLOQUANT		2	2	
5	90170-09M03	.NUT .ECROU		1	1	
6	90387-10M42	.COLLAR .COLLERETTE		1	1	
7	90101-09M01	.BOLT .BOULON		1	1	
8	90201-10M63	.WASHER, PLATE .RONDELLE, PLATE		1	1	
9	6E5-43145-01	.CAP CLAMP BRACKET .CAPUCHON, PRESSE		1	1	
10	93210-16275	.O-RING .JOINT TORIQUE		1	1	

FIG. 30 REMOTE CONTROL BOX

BOITIER DE COMMANDE A DISTANCE

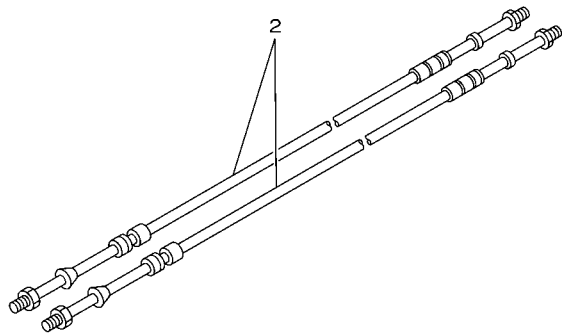
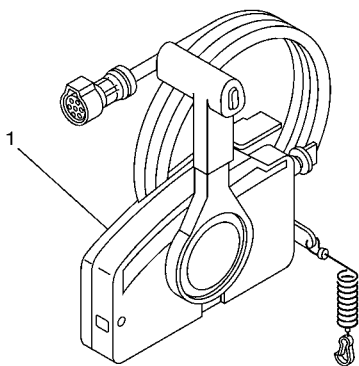

67M0100-8280

REF. NO.	PART NO. N° PIECES	DESCRIPTION DESCRIPTION	MH	E	ET	REMARKS REMARQUES
1	703-48205-A5	REMOTE CONTROL ASSY (10P) BOITIER DE COMMANDE A DISTANCE			1	AP WITH PT/T SW. AP WITH PT/T SW.
	703-48203-A3	REMOTE CONTROL ASSY (7P) BOITIER DE COMMANDE A DISTANCE		1		AP WITHOUT PT/T SW. AP WITHOUT PT/T SW.
2	701-48310-90	CABLE, REMOTE CONTROL L=11F CABLE, COMMANDE A DISTANCE:11F		2	2	UR UR
	701-48320-00	CABLE, REMOTE CONTROL L=12F CABLE, COMMANDE A DISTANCE:12F		2	2	UR UR
	701-48320-20	CABLE, REMOTE CONTROL L=13F CABLE, COMMANDE A DISTANCE:13F		2	2	UR UR
	701-48320-50	CABLE, REMOTE CONTROL L=15F CABLE, COMMANDE A DISTANCE:15F		2	2	UR UR

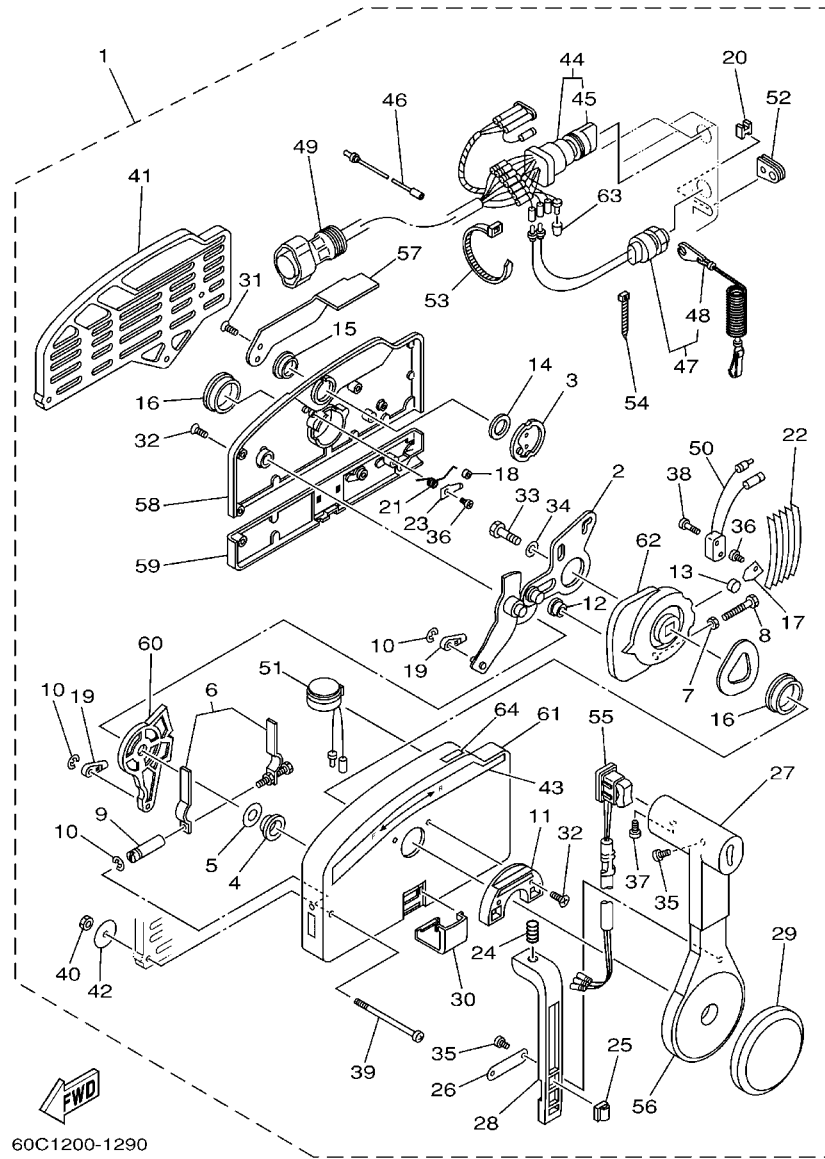

FIG. 31 REMOTE CONTROL ASSY BOITIER DE COMMANDE A DISTANCE

REF. NO.	PART NO. N° PIECES	DESCRIPTION DESCRIPTION	MH	E	ET	REMARKS REMARQUES
1	703-48205-A5	REMOTE CONTROL ASSY (10P) BOITIER DE COMMANDE A DISTANCE			1	AP WITH PT/T SW. AP WITH PT/T SW.
	703-48203-A3	REMOTE CONTROL ASSY (7P) BOITIER DE COMMANDE A DISTANCE		1		AP WITHOUT PT/T SW. AP WITHOUT PT/T SW.
2	703-48261-01	.ARM, THROTTLE .BRAS, ACCELERATION		1	1	
3	703-48153-00	.SHAFT, FREE ACCEL. .AXE		1	1	
4	703-48235-00	.BUSHING .COUSSINET		1	1	
5	703-48268-00	.SPACER .ENTRETOISE		1	1	
6	703-48264-00	.FRICTION, THROTTLE .FRICTION, ACCELERATION		1	1	
7	95380-05600	.NUT .ECROU		1	1	
8	97380-05025	.BOLT .BOULON, HEXAGONAL		1	1	
9	703-48265-00	.SHAFT, FRICTION .AXE, COPILOTE		1	1	
10	93430-06024	.CIRCLIP .CLIPS		3	3	
11	703-48245-00	.PLATE, LOCK .PLAQUE, VERROU		1	1	
12	703-48252-00	.ROLLER, CAM .POULIE		1	1	
13	701-48248-00	.ROLLER, FREE ACCEL. .POULIE		1	1	
14	703-48198-00	.WASHER, WAVE .RONDELLE, ELASTIQUE ONDULEE		1	1	
15	703-48243-00	.BUSHING .COUSSINET		1	1	
16	703-48236-00	.BUSHING 1 .POULIE		2	2	
17	703-48189-00	.RETAINER .FLASQUE		1	1	
18	703-48234-00	.ROLLER, DETENT .POULIE		1	1	
19	703-48345-01	.CABLE END, REMOTE CONTROL 2 .CHAPE CABLE		2	2	
20	703-48358-00	.ANCHOR, CABLE .COLLIER		1	1	
21	703-48244-00	.SPRING, FREE ACCEL. .RESSORT		1	1	
22	703-48238-00	.SPRING, DETENT .RESSORT		5	5	
23	703-48246-00	.SPACER .ENTRETOISE		1	1	
24	703-48227-00	.SPRING, NEUTRAL LOCK .RESSORT		1	1	
25	703-82594-00	.CLAMP .BRIDE			1	WITH PT/T SW. WITH PT/T SW.
26	703-48226-00	.PLATE, STOPPER .PLAQUETTE		1	1	

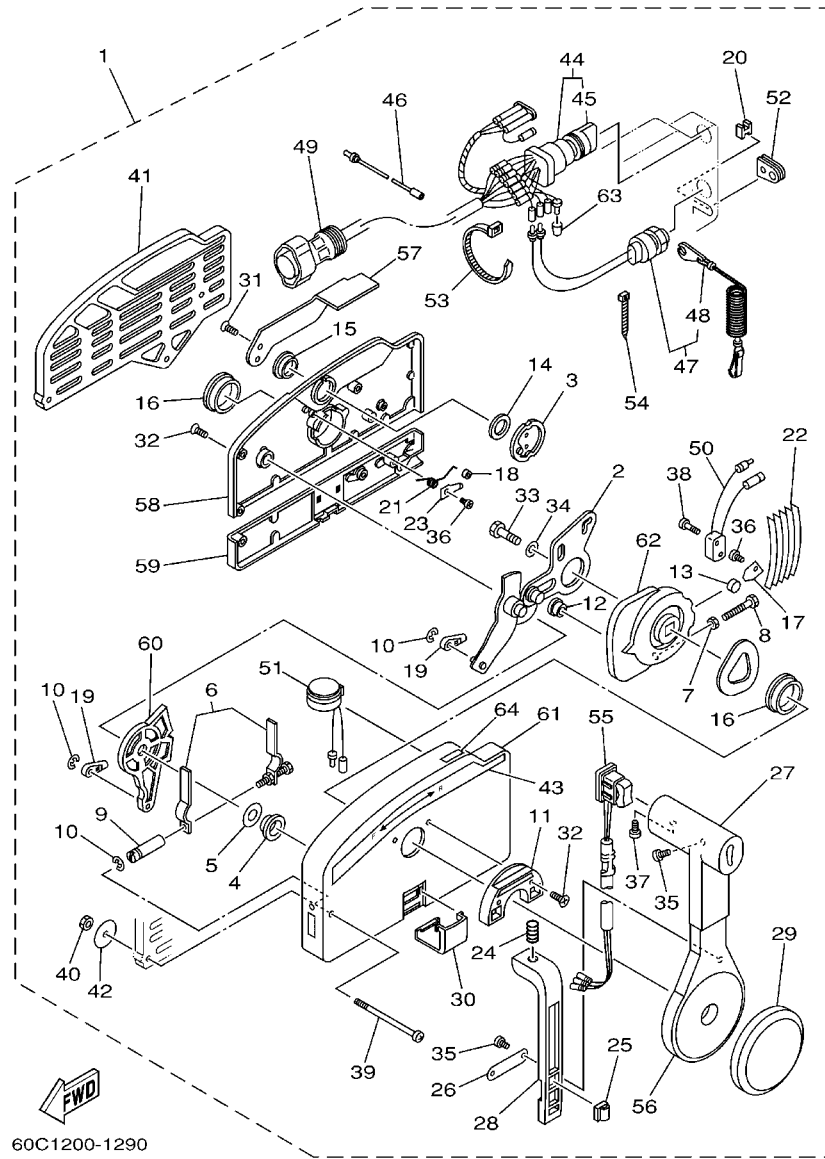
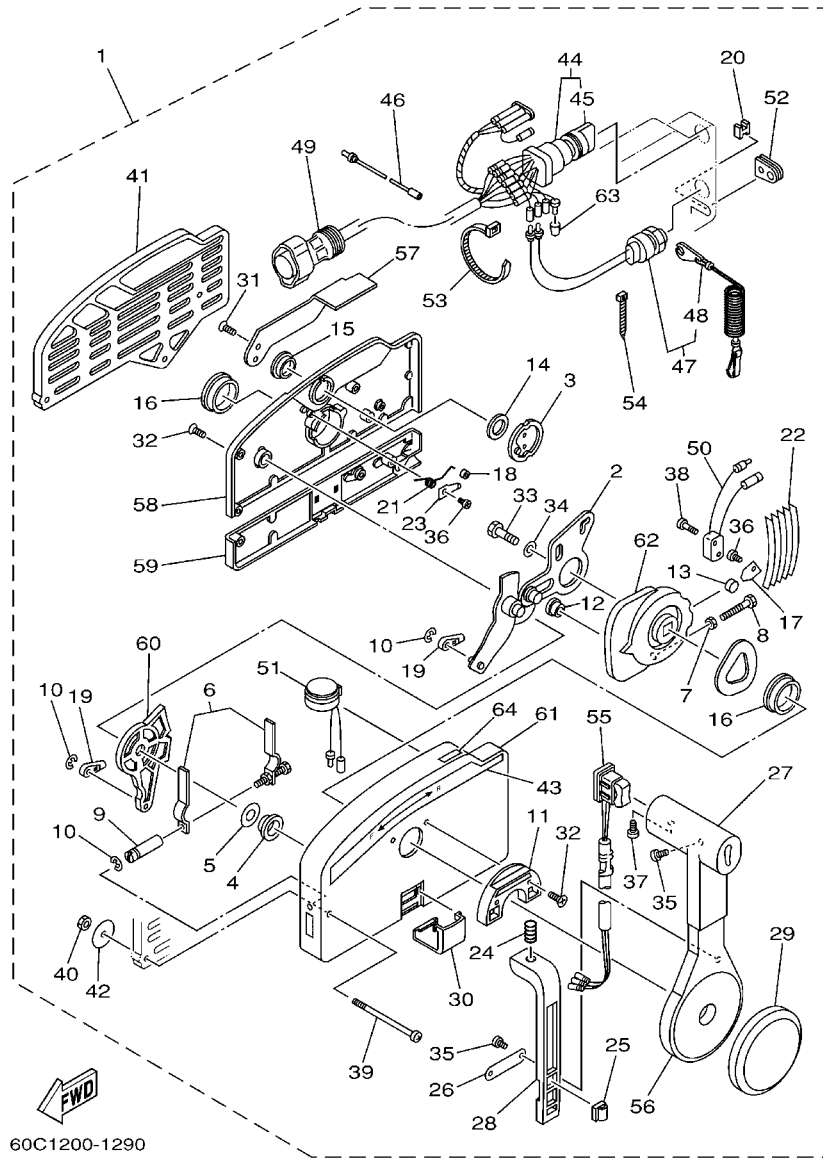

FIG. 31 REMOTE CONTROL ASSY

BOITIER DE COMMANDE A DISTANCE

REF. NO.	PART NO. N° PIECES	DESCRIPTION DESCRIPTION	MH	E	ET	REMARKS REMARQUES
27	703-48222-00	.GRIP, CONTROL LEVER .POIGNEE, COMMANDE LEVIER		1	1	SINGLE SINGLE
28	703-48223-00	.LOCK, NEUTRAL .VERROU, NEUTRAL		1	1	
29	703-48225-00	.COVER .COUVERCLE		1	1	
30	703-48219-00	.COVER, LEAD .COUVERCLE		1	1	
31	703-48281-00	.SCREW .VIS		2	2	
32	703-48282-00	.SCREW .VIS		7	7	
33	97380-08030	.BOLT .BOULON, HEXAGONAL		1	1	
34	92990-08600	.WASHER, PLATE .RONDELLE, PLATE		1	1	
35	98580-04010	.SCREW, PAN HEAD .VIS		3	3	
36	98580-04006	.SCREW, PAN HEAD .VIS		2	2	
37	98580-05010	.SCREW, PAN HEAD .VIS		1	1	
38	98580-03015	.SCREW, PAN HEAD .VIS		2	2	
39	703-48291-10	.SCREW (M6) .VIS (M6)		3	3	
40	95380-06600	.NUT, HEXAGON .ECROU		3	3	
41	703-48293-10	.SPACER, REMOTE CONTROL .ENTRETOISE		1	1	SINGLE SINGLE
42	701-48287-00	.WASHER .RONDELLE		3	3	
43	703-48215-00	.GRAPHIC .ADHESIF		1	1	
44	703-82510-12	.MAIN SWITCH ASSY .CONTACTEUR A CLEF COMPLET			1	PRIME START PRIME START
	703-82510-03	.MAIN SWITCH ASSY .CONTACTEUR A CLEF COMPLET		1		FOR 703-48203-A3 FOR 703-48203-A3
45	676-82577-00	..CAP, KEY ..CABOCHON		1	1	
46	703-82531-00	.WIRE, LEAD (L70) .FIL (L70)		1	1	
47	688-82575-01	.ENGINE STOP SWITCH ASSY .COUPE CIRCUIT CPLT		1	1	
48	682-82556-00	..LANYARD, STOP SWITCH ..PLAQUETTE		1	1	
49	688-8258A-20	.EXTENSION, WIRE HARNESS (4.9M) .EXTENSION, FAISCEAU DE FILS (1	(10P)
	688-82586-21	.EXTENSION, WIRE HARNESS (4.9M) .EXTENSION, FAISCEAU DE FILS (1		(10P) (7P) (7P)
50	703-82540-00	.NEUTRAL SWITCH ASSY .CONTACTEUR DE POINT-MORT		1	1	
51	703-83383-B0	.BUZZER .RONFLEUR		1	1	



60C1200-1290

FIG. 31 REMOTE CONTROL ASSY

BOITIER DE COMMANDE A DISTANCE

REF. NO.	PART NO. N° PIECES	DESCRIPTION DESCRIPTION	MH	E	ET	REMARKS REMARQUES
52	703-48284-00	.GROMMET .PASSE-FIL		1	1	
53	703-82591-00	.BAND .COLLIER		1	1	
54	703-82592-00	.BAND .COLLIER		1	1	
55	703-82563-02	.TRIM & TILT SWITCH ASSY .INCLINER ET PARER COMMUTATEUR			1	WITH PT/T SW. WITH PT/T SW.
	703-48224-00	.COVER, CONTROL LEVER .COUVERCLE		1		WITHOUT PT/T SW. WITHOUT PT/T SW.
56	703-48221-00	.LEVER, CONTROL .LEVIER, COMMANDE		1	1	
57	703-48152-00	.KNOB, FREE ACCEL. .BOUTON		1	1	
58	703-48212-00	.BACK PLATE 1 .PLAQUETTE 1		1	1	
59	703-48213-00	.BACK PLATE 2 .PLAQUETTE 2		1	1	
60	703-48271-00	.ARM, SHIFT .BRAS		1	1	
61	703-48211-01	.HOUSING,1 .CORPS		1	1	
62	703-48232-00	.GEAR .PIGNON		1	1	
63	703-82542-00	.CAP .COUVERCLE		1	1	
64	703-48218-00	.GRAPHIC .ADHESIF		1	1	

FIG. 32 REPAIR KIT 1

KITS DE REPARATION 1

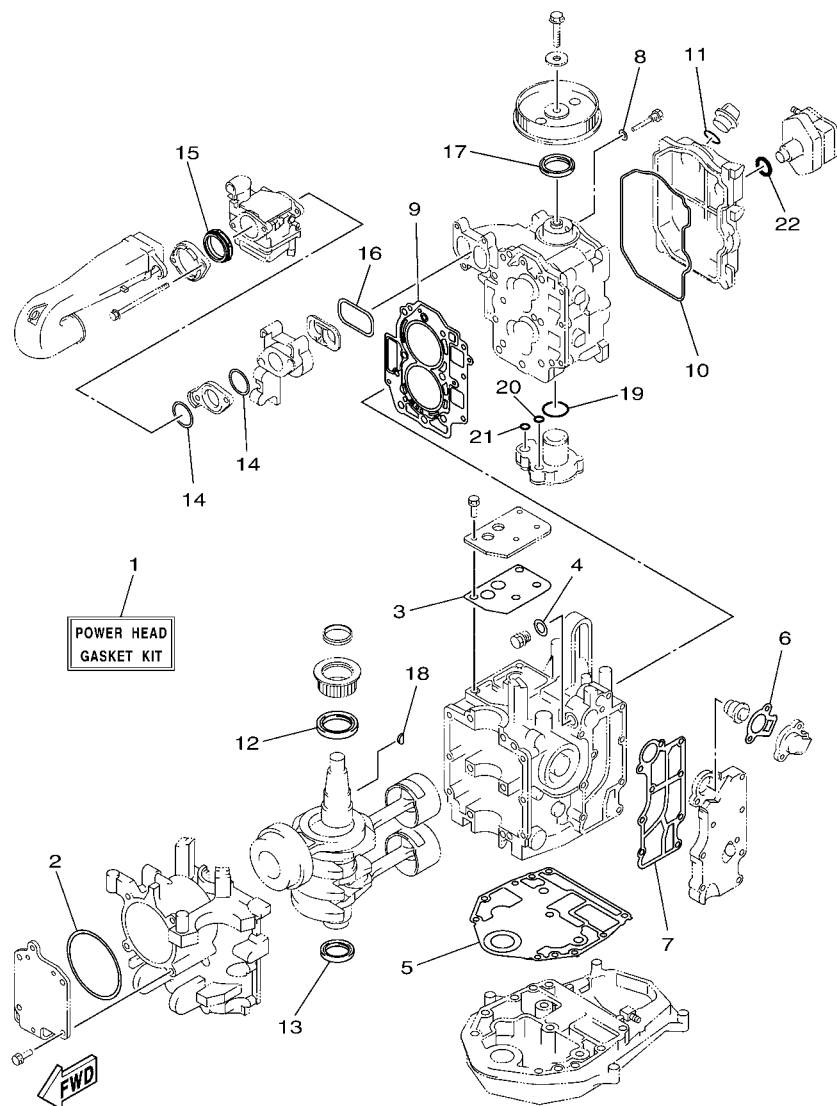

65W8100-G330

REF. NO.	PART NO. N° PIECES	DESCRIPTION DESCRIPTION	MH	E	ET	REMARKS REMARQUES
1	6D5-W0001-00	POWER HEAD GASKET KIT POCHETTE DE JINTS TETE MOTRICE	1	1	1	
2	65W-15663-00	.SEAL .JOINT	1	1	1	
3	65W-11169-01	.GASKET, BREATHER COVER .JOINT, COUVERCLE DE RENIFLARD	1	1	1	
4	90430-14115	.GASKET .JOINT	1	1	1	
5	65W-11351-10	.GASKET, CYLINDER .JOINT, D'EMBASE	1	1	1	
6	62Y-12414-00	.GASKET, COVER .JOINT, COUVERCLE	1	1	1	
7	65W-41114-01	.GASKET, EXHAUST OUTER COVER .JOINT, COUVERCLE D'ECHAPPEMEN	1	1	1	
8	90430-06014	.GASKET .JOINT	1	1	1	
9	65W-11181-30	.GASKET, CYLINDER HEAD 1 .JOINT, DE CULASSE 1	1	1	1	
10	65W-11356-00	.SEAL, CYLINDER 2 .JOINT, SPY CYLINDRE	1	1	1	
11	93210-24M79	.O-RING .JOINT TORIQUE	1	1	1	
12	93102-43004	.OIL SEAL .JOINT SPY	1	1	1	
13	93101-35002	.OIL SEAL .JOINT SPY	1	1	1	
14	65W-14198-00	.GASKET .JOINT	2	2	2	
15	65W-14457-10	.SEAL .JOINT	1	1	1	
16	65W-13645-00	.GASKET, MANIFOLD 1 .JOINT, TUBULURE 1	1	1	1	
17	93102-37M40	.OIL SEAL .JOINT SPY	1	1	1	
18	90280-04M06	.KEY, WOODRUFF .CLAVETTE, DEMI-LUNE	1	1	1	
19	93210-33MH2	.O-RING .JOINT TORIQUE	1	1	1	
20	93210-12MG9	.O-RING .JOINT TORIQUE	1	1	1	
21	93210-14515	.O-RING .JOINT TORIQUE	1	1	1	
22	93210-24M79	.O-RING .JOINT TORIQUE	1	1	1	

FIG. 33 REPAIR KIT 2

KITS DE REPARATION 2

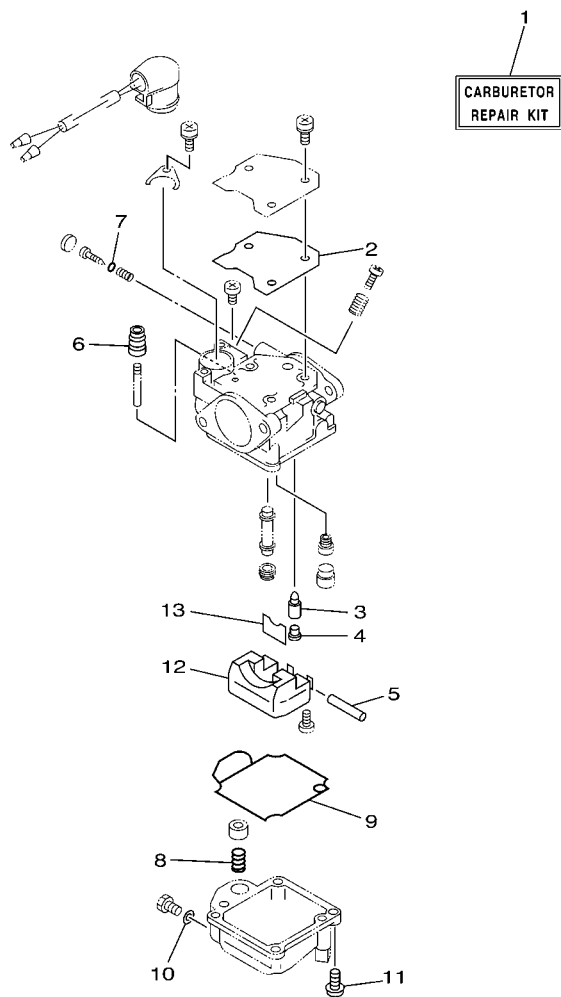

REF. NO.	PART NO. N° PIECES	DESCRIPTION DESCRIPTION	MH	E	ET	REMARKS REMARQUES
1	65W-W0093-02	CARBURETOR REPAIR KIT KIT DE REPARATION CARBURATEUR	1	1	1	
2	65W-14126-10	.GASKET .JOINT	1	1	1	
3	6G1-14546-01	.VALVE, NEEDLE .POINTEAU	1	1	1	
4	676-14186-00	.PIN, FLOAT .AXE, FLOTTEUR	1	1	1	
5	6H4-14548-00	.PIN, FLOAT ARM .AXE, BRAS DE FLOTTEUR	1	1	1	
6	65W-14373-01	.COVER, PLUNGER CAP .COUVERCLE DE PLONGEUR	1	1	1	
7	67C-14397-00	.O-RING .JOINT TORIQUE	1	1	1	
8	65W-14335-00	.SPRING, PLUNGER .RESSORT, PLONGEUR	1	1	1	
9	65W-14384-00	.GASKET, FLOAT CHAMBER .JOINT, CUVE DE FLOTTEUR	1	1	1	
10	65W-14398-00	.GASKET .JOINT	1	1	1	
11	97980-04114	.SCREW, WITH WASHER .VIS, AVEC RONDELLE	4	4	4	
12	63V-14985-00	.FLOAT .FLOTTEUR	1	1	1	
13	663-14159-00	.CLIP .JONC	1	1	1	



65W3100-C360

FIG. 34 REPAIR KIT 3

KITS DE PEPARATION 3

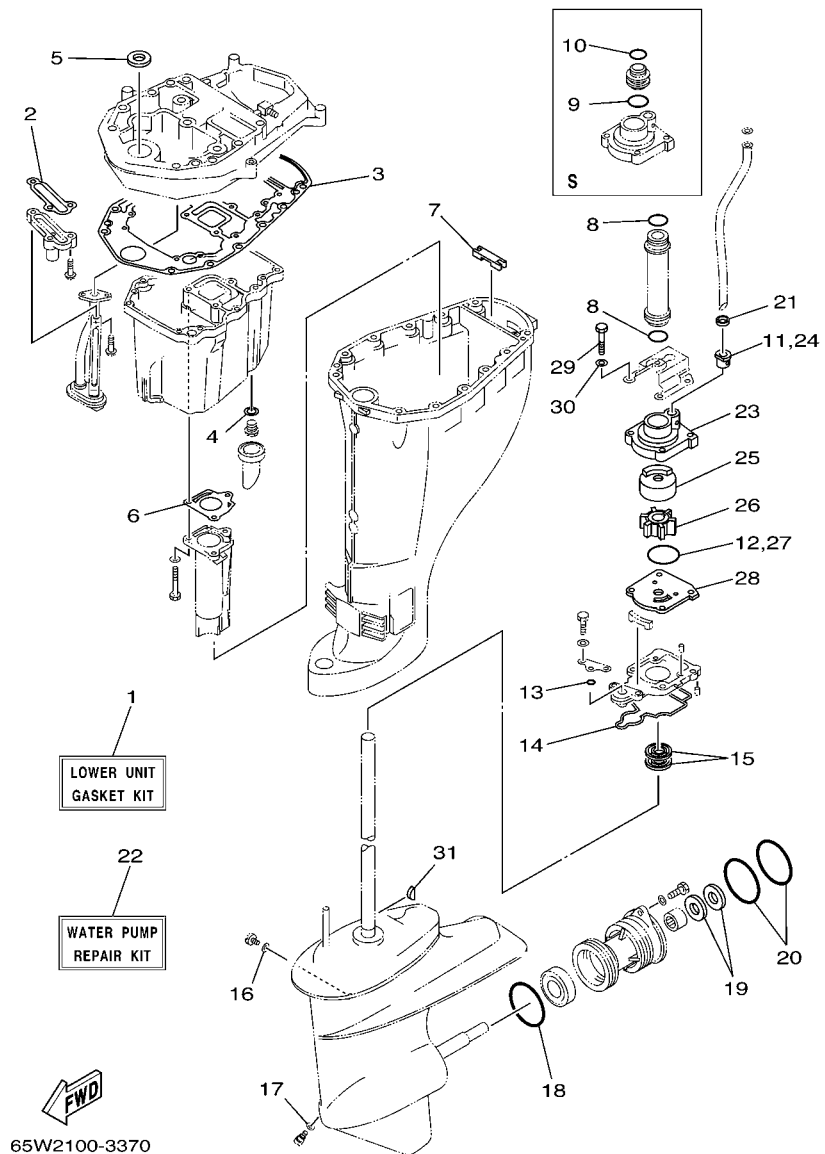

REF. NO.	PART NO. N° PIECES	DESCRIPTION DESCRIPTION	MH	E	ET	REMARKS REMARQUES
1	65W-W0001-23	LOWER UNIT GASKET KIT POCHETTE DE JOINTS EMBASE	1	1	1	
2	62Y-13475-00	.GASKET .JOINT	1	1	1	
3	69W-15312-00	.GASKET, OIL PAN .JOINT DE VENTILATEUR D'HUILE	1	1	1	
4	90430-14M09	.GASKET .JOINT	1	1	1	
5	93110-16004	.OIL SEAL .JOINT SPY	1	1	1	
6	67C-41133-00	.GASKET, EXHAUST MANIFOLD 1 .JOINT, PIPE D'ECHAPPEMENT	1	1	1	
7	65W-45128-00	.SEAL 2 .JOINT 2	1	1	1	
8	93210-26130	.O-RING .JOINT TORIQUE	2	2	2	L(21.6") L(21.6")
9	93210-26130	.O-RING .JOINT TORIQUE	1	1	1	S(16.6") S(16.6")
10	93210-22164	.O-RING .JOINT TORIQUE	1	1	1	S(16.6") S(16.6")
11	6L2-44367-00	.DAMPER, WATER SEAL .JOINT TUBE D'EAU	1	1	1	
12	93210-45161	.O-RING .JOINT TORIQUE	1	1	1	
13	93210-06ME6	.O-RING .JOINT TORIQUE	1	1	1	
14	61N-45315-00	.PACKING, LOWER CASING .JOINT, BOITIER D'HELICE	1	1	1	
15	93101-22067	.OIL SEAL .JOINT SPY	2	2	2	
16	90430-08020	.GASKET .JOINT	1	1	1	
17	90430-08020	.GASKET .JOINT	1	1	1	
18	93210-64ME7	.O-RING .JOINT TORIQUE	1	1	1	
19	93101-20M07	.OIL SEAL .JOINT SPY	2	2	2	
20	93210-65M50	.O-RING .JOINT TORIQUE	2	2	2	
21	90430-10002	.GASKET .JOINT	1	1	1	
22	61N-W0078-11	WATER PUMP REPAIR KIT KIT DE REPARATION DE LA POMPE	1	1	1	
23	61N-44311-01	.HOUSING, WATER PUMP .CORPS, POMPE A EAU	1	1	1	
24	6L2-44367-00	.DAMPER, WATER SEAL .JOINT TUBE D'EAU	1	1	1	
25	61N-44322-01	.INSERT, CARTRIDGE .CUVETTE	1	1	1	
26	6H4-44352-02	.IMPELLER .TURBINE	1	1	1	
27	93210-45161	.O-RING .JOINT TORIQUE	1	1	1	

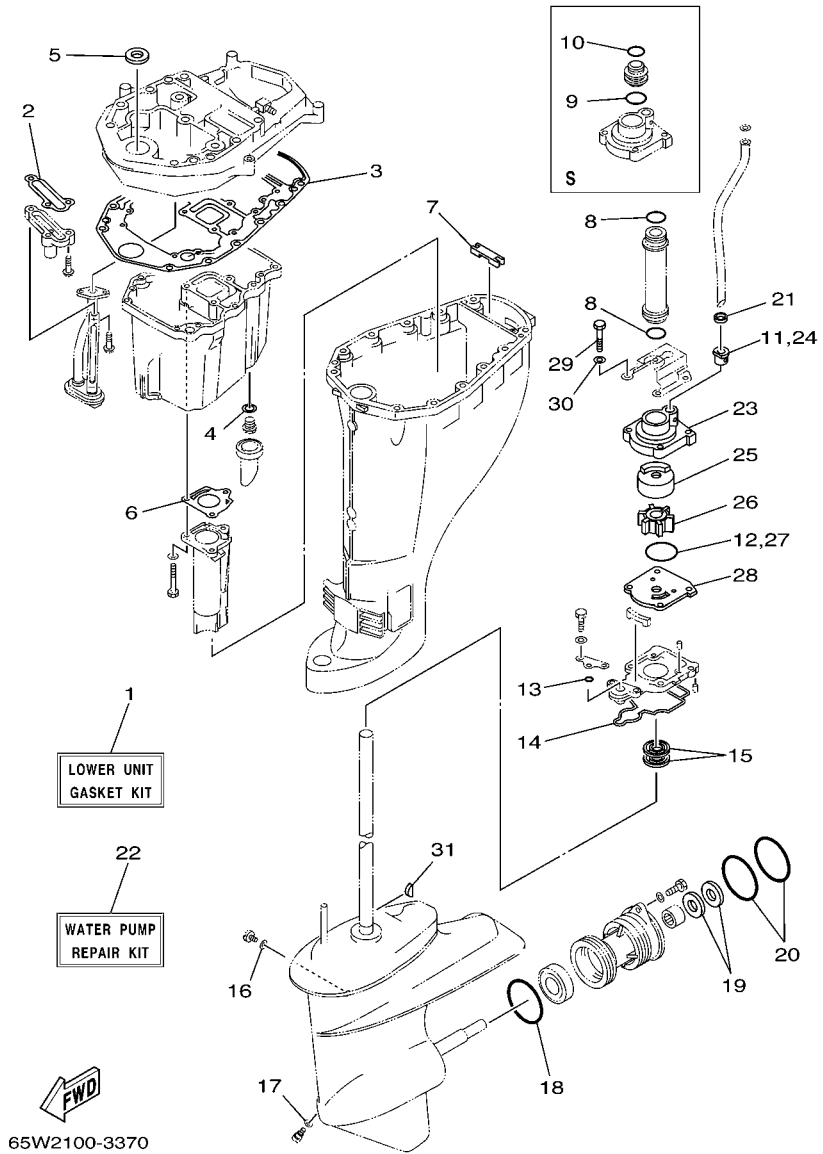

FIG. 34 REPAIR KIT 3

KITS DE REPARATION 3

REF. NO.	PART NO. N° PIECES	DESCRIPTION DESCRIPTION	MH	E	ET	REMARKS REMARQUES
28	61N-44323-00	.OUTER PLATE, CARTRIDGE .PLAQUE EXTERIEURE	1	1	1	
29	97095-06040	.BOLT .BOULON	4	4	4	
30	92995-06600	.WASHER .RONDELLE	4	4	4	
31	90280-03024	.KEY, WOODRUFF .CLAVETTE, DEMI-LUNE	1	1	1	

